



i-ALERT[®] 2

Equipment Health Monitor



Application Guide



ITT

ENGINEERED FOR LIFE

TABLE OF CONTENTS

- INTRODUCTION..... 4**
 - HOW I-ALERT2 MONITOR AUGMENTS A CONDITION MONITORING PROGRAM..... 6
 - Improved Program Efficiency 6
 - Improved Program Effectiveness..... 6
 - Improved Worker Safety 6
- RELIABILITY OVERVIEW 7**
 - INTRODUCTION TO CONDITION MONITORING..... 8
 - Step 1.NOTICE: Detection of Problems*..... 9
 - Step 2.INVESTIGATE: Analyze the problem* 9
 - Step 3.RESOLVE: Correction and Improvement*..... 10
 - Step 4.DOCUMENT* 10
- SYSTEM OVERVIEW 11**
 - DEVICE TECHNOLOGY BACKGROUND 11
 - Device Overview* 12
 - Vibration and Temperature Specifications 12
 - Trending Specifications 12
 - Hardware Specifications 12
- APPLICATION BEST PRACTICES 13**
 - CHOOSING THE CORRECT MEASURES AND ASSETS 13
 - Equipment Criticality*..... 13
 - Machine selection criteria* 14
 - Where to Start? 15
 - Condition Monitoring Measures* 16
 - Temperature..... 16
 - Vibration – RMS Velocity 16
 - Kurtosis 17
- INSTALLATION BEST PRACTICES..... 18**
 - MOUNTING LOCATIONS..... 18
 - General Guidelines* 18
 - i-frame pump*..... 19
 - End suction pump*..... 20
 - Horizontal Electric Motors*..... 21
 - Between Bearings pump* 22
 - Vertical Electric Motors* 23
 - Vertical Pump* 24
 - Mixers*..... 24
 - Vacuum Pumps*..... 24
 - MOUNTING METHODS 25
- COMMISSIONING..... 25**
 - STEPS TO ACTIVATE THE I-ALERT2 EQUIPMENT HEALTH MONITOR: 25

TO RESET THE I-ALERT2:.....	26
I-ALERT2 EQUIPMENT HEALTH MONITOR ROUTINE OPERATION.....	27
I-ALERT2 EQUIPMENT HEALTH MONITOR TROUBLESHOOTING.....	27
I-ALERT2[®] MOBILE APP OPERATION	28
INSTALLING THE APP	28
CONNECTING TO I-ALERT2 DEVICES.....	28
DASHBOARD.....	31
TRENDING.....	32
<i>Weekly View</i>	37
<i>Kurtosis</i>	38
ADVANCED TOOLS.....	39
<i>FFT and TWF Data</i>	40
<i>Stored and Alarm Generated FFT Data</i>	41
EQUIPMENT INFORMATION.....	42
<i>Alarms / Warnings</i>	42
<i>Equipment Details</i>	44
<i>Parts List / BOM</i>	45
<i>Pump Curve</i>	46
<i>Commands</i>	47
REPORT GENERATOR.....	48
HELP/FAQ.....	50
SERVICE LOCATOR.....	51
USER SETTINGS.....	52
TECHNICAL REFERENCES.....	52

INTRODUCTION

This guide is designed to assist reliability practitioners in optimizing the performance of their rotating equipment assets using modern condition monitoring technologies.

Traditional condition monitoring techniques and budget constraints force practitioners to make difficult choices as to which pieces of equipment they can focus on while relegating many of the less critical assets to a suboptimal time based maintenance regime or a “fix it when it breaks” mentality. Even in those plants that do perform periodic predictive maintenance (PdM) inspections, the frequency or time between inspections is a month or more, sometimes up to a year. Many failure mechanisms can develop and progress into catastrophic failure well before the next inspection, rendering the PdM program ineffectual for “balance of plant” equipment.

Using the latest Micro-Electromechanical Sensors (MEMS) and Bluetooth® wireless communications technologies ITT has created a tool *that better fits the needs of reliability practitioners.*

Continuous monitoring of machinery health is an ideal solution to prevent unplanned downtime, but has historically come with a big price tag that couldn't be justified except on the most critical assets. Using the latest Micro-Electromechanical Sensors (MEMS) and Bluetooth® wireless communications technologies ITT has created a tool to better fit the needs of reliability practitioners. The i-ALERT2 Equipment Health Monitor is a low cost alternative that continuously trends key machinery health parameters including overall vibration and temperature and allows users to access that trend data during routine inspections. Leveraging new technology allows the i-ALERT2 condition monitor to offer improved utility and reduced cost compared to a typical “walk-around” monthly vibration program.

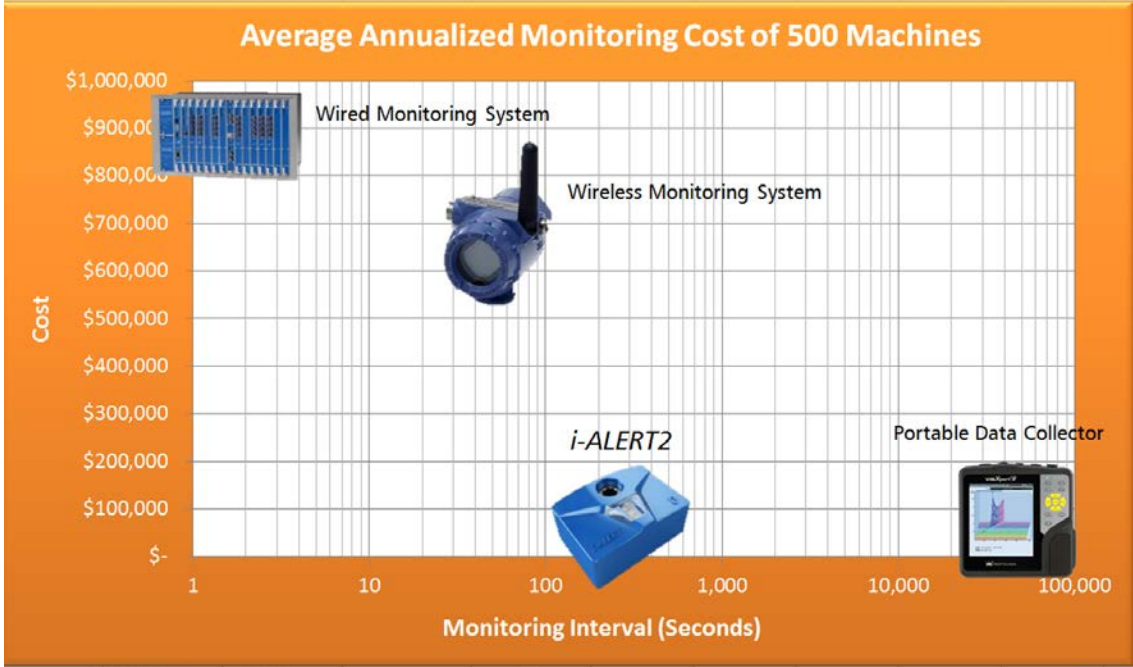
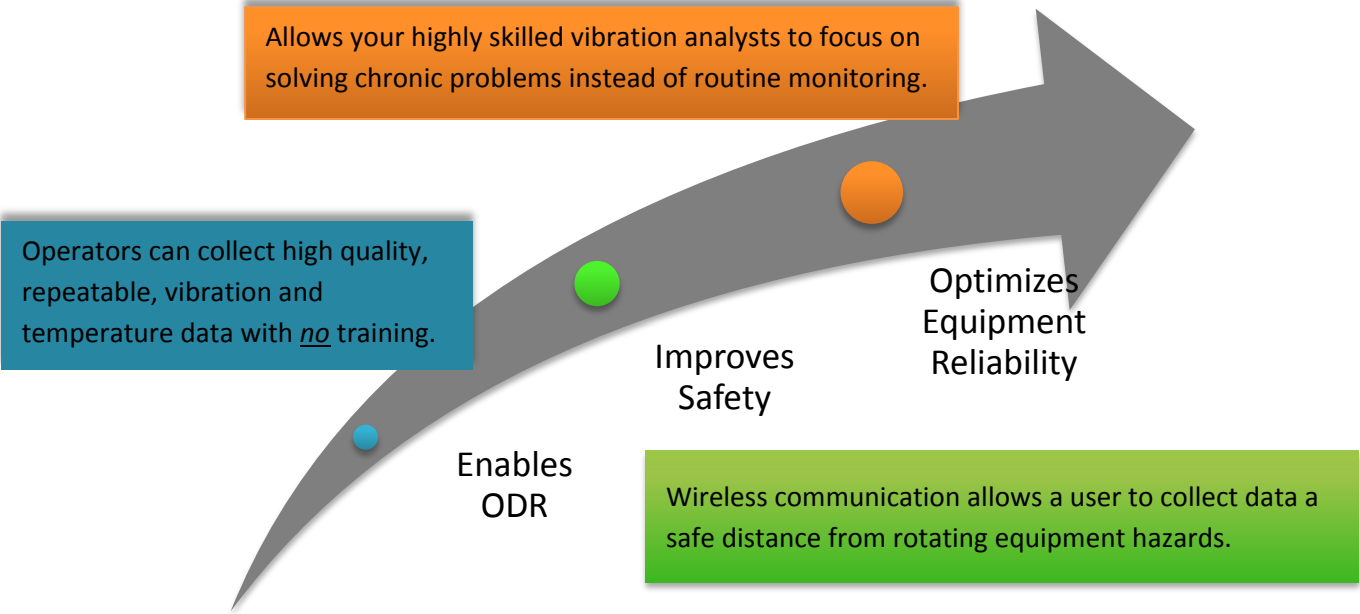

Figure 1: Condition Monitoring Technology Comparison



IMPROVED PROGRAM EFFICIENCY

- Faster data collection and less time spent walking routes because the need to physically mount a temporary sensor is eliminated.
- Easily visible indication of equipment condition during data collection through the device's onboard LEDs.
- Data collection can be easily integrated into existing operator rounds.
- Allows your highly skilled vibration analysts to focus on solving chronic problems instead of routine monitoring. This is becoming increasingly more important as these skill sets are in short supply.
- Users can simultaneously view any machine's current overall condition for any device in range. No need to actually touch each machine to get the data.

IMPROVED PROGRAM EFFECTIVENESS

- Continuous data collection allows for diagnosis of transient and process related problems which are traditionally very hard if not impossible to spot with monthly or quarterly data collection cycles. Especially effective for batch process equipment.
- Traditional monthly walk around monitoring with a portable data collector requires at least 2 months to generate 2 points or a "trend" upon which a baseline condition can be established. In 2 months, the i-ALERT2 monitor can measure and store 720 points, giving the PDM practitioner a superior level of confidence and understanding of the equipment's behavior.
- Changes in machine state automatically trigger the device to capture spectral and time waveform data. The ability to capture this diagnostic data in conjunction with the trend and timestamp information improves a reliability practitioner's ability to troubleshoot process related problems.
- Temperature and Kurtosis trending enhance the traditional overall vibration dataset, yielding more accurate condition assessment than overall RMS vibration alone.

IMPROVED WORKER SAFETY

- No need to get close to dangerous rotating equipment hazards to collect the data. Just be in the same room with it.

RELIABILITY OVERVIEW

Maintenance and Reliability (M&R) practices including condition monitoring are largely governed by the type of assets being maintained and the associated failure patterns of those assets. Numerous studies have been conducted in both the Industrial and Aeronautical / Military markets that show the relative frequency or “probability” of failure of equipment. This data is summarized in Figure 2. What should immediately become apparent is that very few failures are attributable to “wearing out” or what might be termed an “age-related” failure¹ pattern.

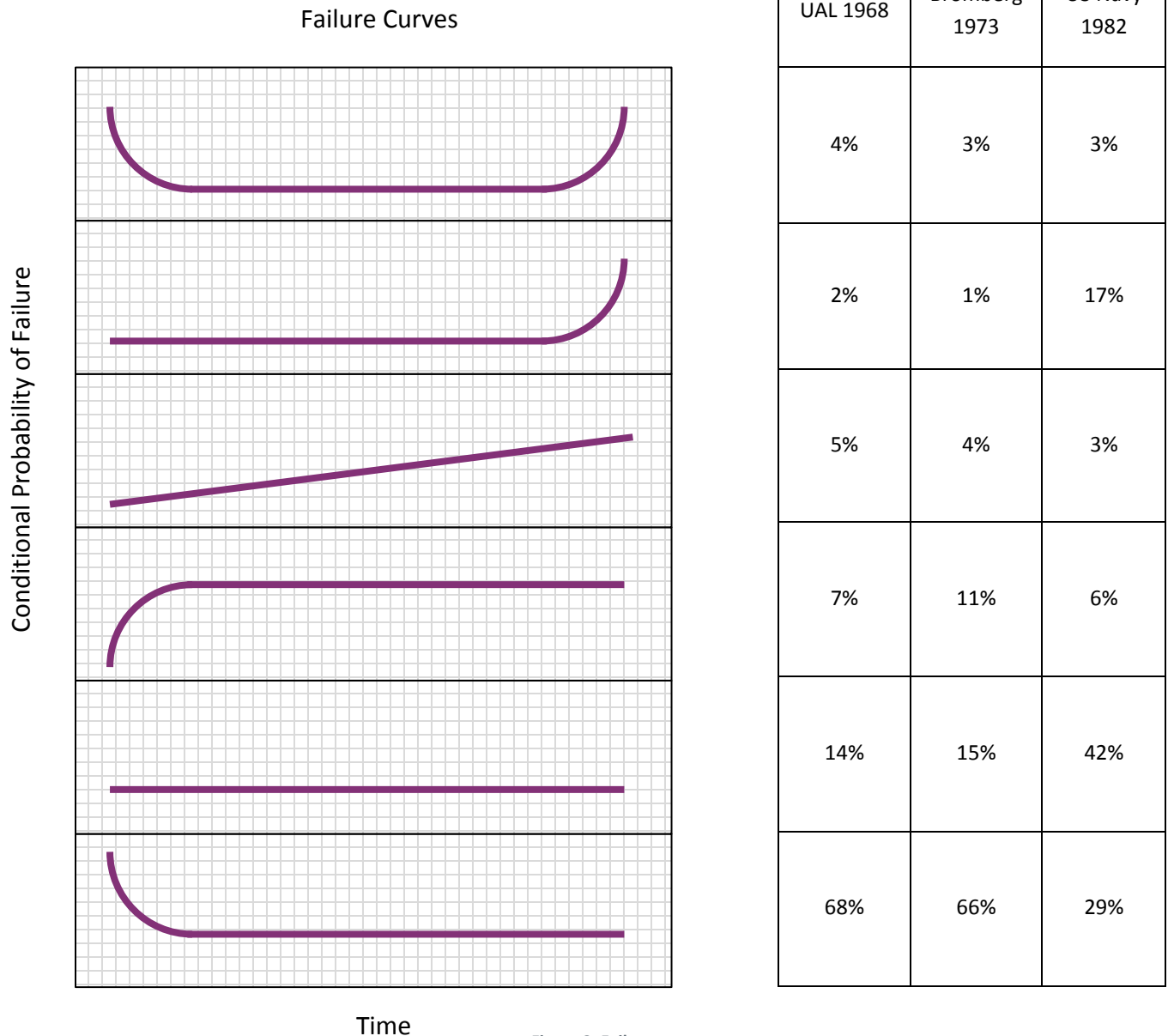

Figure 2: Failure curves

¹ Those that are age-related are almost all corrosion in seawater applications with a relatively predictable lifecycle.

The majority of industrial equipment will tend to have a failure probability distribution similar to that of Figure 3, where the risk of failure for equipment is highest upon startup, sometimes termed “infant mortality” and will decrease to some relatively constant probability of failure over time.

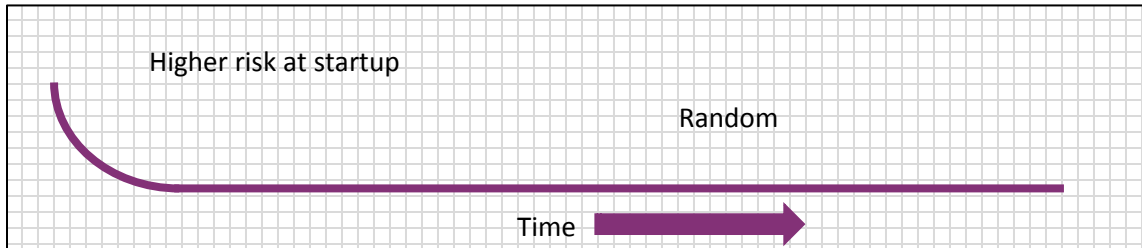

Figure 3: Most common failure probability pattern for industrial equipment

Knowing that most equipment will follow the failure pattern of Figure 3 should guide M&R practitioners to select condition monitoring equipment that can:

1. Quickly identify defects or problems when new equipment is started before they cause severe damage
2. Help establish confidence that a newly commissioned machine is operating within specific limits
3. Maximize the ability to detect randomly occurring failures after a successful startup.

The i-ALERT2 Equipment Health Monitor is designed to provide all of these functions while still maintaining cost effectiveness. Always consider the benefits a new condition monitoring technology will provide against these proven failure curves to ensure it will be effective. Implementing new technology just for the sake of saying you have the latest and greatest technology will lead to a lot of wasted money and effort.

INTRODUCTION TO CONDITION MONITORING

CM and PdM tools available today are great enhancements to the traditional visual / audible Inspections and augment regular operators’ inspections. Whether performing a simple visual inspection or using the most sophisticated tools available the process is fundamentally the same. There are 4 Steps:

- **NOTICE**
 - We have to notice or detect that we have a problem with a piece of equipment.
- **INVESTIGATE**
 - Once detected, we can investigate and analyze the problem to determine the root cause.
- **RESOLVE**
 - After determining the root cause, we can correct the problem and, if possible, improve the machine by leaving it in a precise state.
- **DOCUMENT**
 - By documenting our results, we are able to verify that the problem has been solved and communicate our successes to others.

It is important to thoroughly understand each of these steps. Valuable time is often wasted when too much emphasis is placed on any one component.

STEP 1. NOTICE: DETECTION OF PROBLEMS

Since analysis of machine problems is a time consuming process and there are many machines in a typical plant, it is important **NOT** to try to analyze all machines. The first step in an effective condition monitoring program is to identify the problem machines. This is the purpose of the detection phase of the program. Measurements and machines are organized into a series of logical routes and data is collected on them in a routine manner. Route functionality is a cornerstone of the i-ALERT2 condition monitor's value. One of the strengths of the i-ALERT2 monitor is the ability to broadcast the machine's condition without having to wirelessly connect to it. The data collected is designed to indicate when a change has occurred or when a preset limit has been exceeded. After the data has been collected, it is reviewed and exceptions are noted and reported.

After identifying machines in need of further analysis using detection, the next step is to determine the root cause of the problem. This is achieved during the INVESTIGATE or ANALYSIS phase.

Figure 4: Simultaneously view states of all devices in range

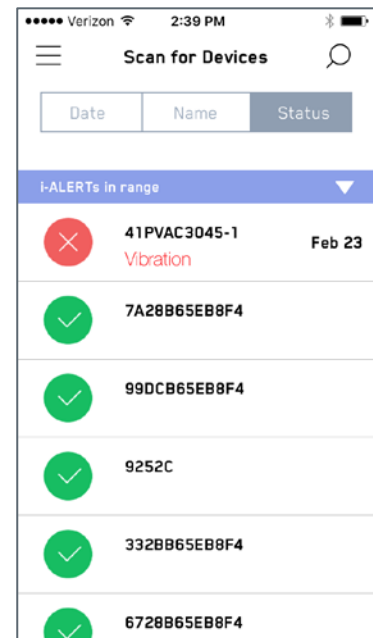

STEP 2. INVESTIGATE: ANALYZE THE PROBLEM

The analysis phase involves gathering more detailed diagnostic data which can include process conditions, flows, pressures, FFT, TWF, Timestamps and Trend data. Performing such analysis is a time consuming process and should NOT be attempted on all machines, only the ones that have exceeded alarm limits.



Figure 5: Process data related to condition monitoring data

If process data is available from the control system it should be overlaid with the vibration/temperature trends of the i-ALERT2 to help determine root cause. Often the root cause of a vibration problem is a process upset.

STEP 3.RESOLVE: CORRECTION AND IMPROVEMENT

After determining the root cause of the problem, it can be corrected. Cost effective corrective actions will depend on the machine in question and the findings of the failure analysis. In order to maximize the reliability of the machine in question, it is also advisable to improve the vibration levels on the machine to “precision state” levels after it has been repaired. This will extend the life of the machine.

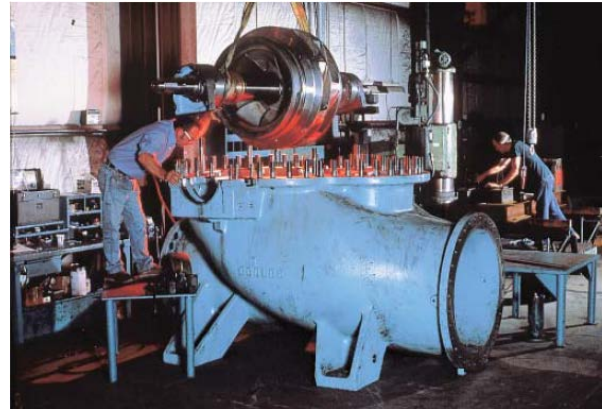

Figure 6: Precision repair at an ITT PRO Service center

STEP 4.DOCUMENT

After determining the root cause of the problem, correcting the problem and improving the machine, it is important to *verify* that the correction/improvement has occurred and document the findings. One mechanism for this verification is comparing the vibration levels after restarting the machine with those taken before shutdown and the original baseline data. Other common verification methods include:

- Measuring reduced energy consumption
- Capturing Infrared Thermography Images
- Oil analysis
- Confirming precision alignment

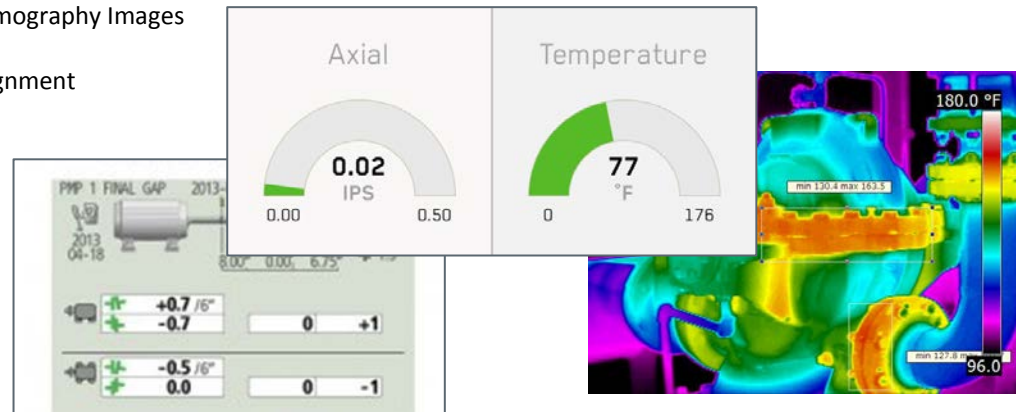

Figure 7: Document results to verify corrective action was effective

SYSTEM OVERVIEW

DEVICE TECHNOLOGY BACKGROUND

Micro-Electro-Mechanical Systems, or MEMS, is a technology that is best defined as miniaturized mechanical and electro-mechanical elements that are made using the techniques of microfabrication. MEMS represent the next generation of sensing technology. OEMs in all industries including automotive, industrial and aerospace are migrating away from older macro-scale transducers due to the various advantages MEMS can provide. The physical dimensions of MEMS devices can be less than a micron up to several millimeters. MEMS devices can vary from relatively simple structures having no moving elements, to extremely complex electromechanical systems with multiple moving elements under the control of integrated microelectronics. One of the most prevalent uses for MEMS is the construction of miniaturized sensors that convert energy from one form to another, known as transducers. In the case of MEMS sensors, the device typically converts a measured mechanical signal into an electrical signal.

Over the past several decades a large number of micro-sensors have been developed for almost every type of physical measurement including temperature, pressure, inertial forces, vibration, magnetic fields, etc. Surprisingly many of these MEMS sensors have proven to be more accurate and precise than their macro-scale counterparts. In example, the MEMS version of a pressure transducer usually outperforms a pressure sensor made using the most precise macro-scale level machining techniques. Not only is the performance of MEMS devices exceptional, but their method of production leverages the same batch fabrication techniques used in the integrated circuit industry – which translates into low per-unit production costs.

The latest generation of MEMS includes micro-sensors, micro-actuators and micro-electronics integrated onto a single microchip. This has resulted in the explosive development of smart products which integrate computing intelligence with sensing and control. Because MEMS devices are manufactured using batch fabrication techniques, similar to integrated circuits, high levels of reliability are being achieved at very low costs. The i-ALERT2 monitor leverages recent advancements in MEMS vibration transducers to achieve impressive performance at a minimum cost. The sensors' data gathering capabilities are then mated to another leading technology known as Bluetooth Smart or Bluetooth Low Energy.

Bluetooth is a wireless signal protocol that was first developed in 1994 as a way for computers to communicate to other devices without cables. Bluetooth is an open standard that allows disparate devices to communicate using the same "language". Over the last few decades the technology has been steadily improved to be able to transmit more data faster while simultaneously reducing the amount of power the wireless radios consumed. Bluetooth Smart allows tiny batteries to power wireless radios for years at a time without recharging and is one of the technologies enabling the rapid rise of the Industrial Internet of Things (IIOT). IIOT is a term that describes the reality of hundreds (or thousands) of smart devices communicating hordes of data to enable smarter, more efficient operations.

Many of the existing condition monitoring hardware manufacturers are aware of the potential for MEMS and Smart sensors however they are reluctant to offer this new technology due to the potential for cannibalization of their existing macro-scale sensor products. ITT is free from this commercial constraint and will continue to utilize the best and latest technology that allows our customers to optimize the reliability of their rotating equipment assets.

DEVICE OVERVIEW

The i-ALERT2 Equipment Health Monitor is a compact, battery-operated monitoring device that continuously measures the vibration and temperature of a piece of rotating equipment. The i-ALERT2 Equipment Health Monitor uses blinking red LED and wireless notification to alert operators when the equipment exceeds vibration and temperature limits. This allows the operator to make changes to the process or the equipment before catastrophic failure occurs. The Equipment Health Monitor is also equipped with a single green LED to indicate when it is operational and has sufficient battery life.

The i-ALERT2 Equipment Health Monitor also contains a Bluetooth radio that communicates to certain Bluetooth 4.0 equipped devices through a mobile application. Data is shared between the i-ALERT2 Equipment Health Monitor, the mobile application, phone, and the data servers.

The i-ALERT2 Equipment Health Monitor will communicate sensor related data (such as vibration, temperature, runtime information, and device statistics) stored in the device to the mobile application. The mobile application will send commands to the device.

The Mobile application will back up device data as well as app usage information on the data servers. The data servers will send the mobile application equipment technical data. For full details about data storage and rights please review the Privacy Policy.

Alarm mode

The i-ALERT2 Equipment Health Monitor enters alarm mode when either vibration or temperature limits are exceeded over two consecutive readings within a 10 minute period. Alarm mode is indicated with 1 (one) red flashing LED within 2 (two) second intervals.

Warning and Alarm Values Variable	Limit
Temperature (default)	80°C (176°F)
Vibration Alarm (0.1-1.5 ips)	100% increase over the baseline level
Vibration Warning (0.1-1.5 ips)	75% increase over the baseline level

Table 1: Default Alarm Values

VIBRATION AND TEMPERATURE SPECIFICATIONS

- Axial / Horizontal Sensor Frequency Range 10 Hz to 1000 Hz
- Radial Sensor Frequency Range 10 Hz to 600 Hz
- 15g Dynamic Range
- Spectral vibration measurements have a frequency bandwidth resolution of 1 Hz.
- Amplitude accuracy +/- 10%
- Diagnose machine faults with vibration tools Fast Fourier Transform & Time Waveform analysis
- Maximum temperature of 183°F

TRENDING SPECIFICATIONS

- Sensors and onboard memory tracks vibration, temperature, & run-time hours continuously
- Devices checks every five minutes & alarms if equipment is outside normal operating conditions
- Stores data once per hour & on alarm for 30 days
- Stores the weekly average, minimum & maximum up to 5 years
- Calculates and stores Kurtosis values

HARDWARE SPECIFICATIONS

- Rated for most industrial environment. IP67 water & dust resistant. Class 1 Division 1, ATEX Certified

- Intrinsically Safe with a 3 year battery life (use dependent).
- The following determines the “normal operating conditions” in which the 3 year battery life is determined:
 - Temperature: 18°C (65°F)
 - Dashboard connections (including trend download): Once per day
 - FFT and Time Waveform usage: One tri-axial request per 14 days
 - Operation time in Alarm: 25% of time
- Sync data via Bluetooth Smart enabled smartphones and tablets.
- Wireless Range Approximately 10m (33ft) to 30m (100ft)

APPLICATION BEST PRACTICES

CHOOSING THE CORRECT MEASURES AND ASSETS

EQUIPMENT CRITICALITY

The initial step in building a predictive maintenance program is to identify which systems will be analyzed and prioritizing the order in which the analysis will take place. To get the most return on the time invested, the most logical place to start is with the equipment hierarchy that exists in the Computerized Maintenance Management System (CMMS). This is typically a breakdown of all existing equipment from Plant Level to Business Unit to Operating System to Equipment to Component and to Sub-component, where necessary.

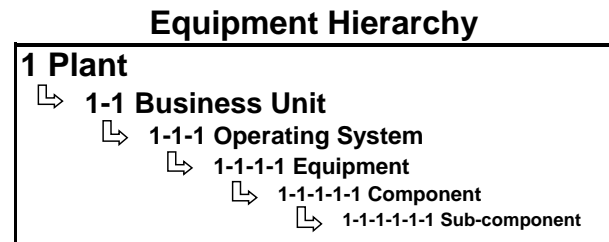

Figure 8: Example Asset Hierarchy for a CMMS

For a first cut at prioritization for the analysis, it is practical to review the hierarchy at the Operating System level to determine which systems are *business critical* to the organization.

Business Critical - A failure of that specific system at the operating system level would have a direct and immediate financial impact on the facility output.

For systems deemed critical, a full Reliability Centered Maintenance (RCM) analysis should be performed. One approach to determine criticality is to use tables similar to those below to assess consequence and probability.

Consequence (Severity) Comment			Relative Probability of Occurrence		
10	Hazard	Potential Safety, Health or Environmental issue. Failure will occur <u>without</u> warning.	10	Very High	Very High failure rate. Almost certain to cause problems.
9	Hazard	Potential Safety, Health or Environmental issue. Failure will occur <u>with</u> warning.	9	High to Very High	High to very high failure rate. Highly likely to cause problems.
8	Very High	Very high disruption to facility function. All of Production is lost. Significant delay in restoring function.	8	High	High failure rate. Similar to past design that has, in the past, had high failure rates that have caused problems.
7	High	High disruption to facility function. Some portion of Production is lost. Significant delay in restoring function.	7	Moderate to High	Moderate to high failure rate. Similar to past design that has, in the past, had high failure rates that have caused problems.
6	Moderate to High	Moderate disruption to facility function. Some portion of Production is lost. Moderate delay in restoring function.	6	Moderate	Moderate failure rate. Similar to past design that has, in the past, had moderate failure rates for given volume.
5	Moderate	Moderate disruption to facility function. 100% of Production may need to be reworked or process delayed.	5	Occasional to Moderate	Occasional to moderate failure rate. Similar to past design that has, in the past, had moderate failure rates for given volume.
4	Low to Moderate	Moderate disruption to facility function. Some portion of Production may need to be reworked or process delayed.	4	Occasional	Occasional failure rate. Similar to past design that has, in the past, had similar failure rates for given volume.
3	Low	Minor disruption to facility function. Repair of failure may be longer than trouble call but does not delay Production.	3	Low	Low failure rate. Similar to past design that has, in the past, had low failure rates for given volume.
2	Very Low	Minor disruption to facility function. Repair of failure can be accomplished during trouble call.	2	Very Low	Very low failure rate. Similar to past design that has, in the past, had very low failure rates for given volume.
1	None	No reason to expect failure to have any effect on Safety, Health, Environment or Production.	1	Remote	Remote probability of occurrence; unlikely for failure to occur.

Table 2: Example of RCM Methodology based on consequence and probability of failure

Risk is defined as Probability x Consequence. So by multiplying the assigned values from each table a criticality number can be determined.

The value assigned for equipment will be based on the consequence of the failure of the equipment (called Severity) multiplied by the probability that the failure will occur (called Probability). The **asset matrix** (list of all assets that have had the business criticality determined) can then be sorted by priority. The equipment with the largest number as figured by Severity x Priority is the most business critical equipment.

MACHINE SELECTION CRITERIA

Just as with every existing condition monitoring system, there are certain applications that best fit the technology being leveraged. For instance, monitoring casing vibration on a large, slow moving shaft mounted in fluid film bearings would yield very little quality information as to the health of the machinery. In order to maximize the return on investment for any given CM system, it has to be applied to the correct machinery. The following tables and comments help illustrate the best fits for the i-ALERT2 condition monitoring system.

Equipment Type	Good	Limited
Centrifugal Pumps		
Positive Displacement Pumps		
Electric Motors		
Fans / Blowers		
Paper Machine Bearings		
Centrifugal Compressor		
Reciprocating Compressors		Low Speed Limitations
Engines		
Steam Turbines		Casing Temperature
Gearbox / Reducers		Mesh Frequency

Table 3: Recommended machinery applications for i-ALERT2 (Note: Shaft Speeds must be greater than 600 RPM)

Some general limitations to keep in mind when selecting machinery are:

- The i-ALERT2 monitor is designed to measure casing vibration, so machines with sleeve/fluid-film bearings are inherently not going to be as good a fit due to attenuation of the shaft vibration via the fluid-film. Now that does not mean i-ALERT2 cannot be used for sleeve bearing machinery, only that the casing vibration measured will not reflect the true shaft vibration amplitudes.

- The upper and lower frequency cutoffs for the i-ALERT2 devices are 1000 Hz and 10 Hz respectively. Just as with any condition monitoring instrumentation, it is recommended that the machinery shaft speed and primary potential fault frequencies fall within this range. For diagnostic purposes, you want to be able to see more than just the shaft speed and ITT recommends a minimum frequency range of 10x the shaft speed, AKA the first order. This translates to an effective upper limit on shaft speeds of 6,000 RPM. It can be applied on higher speed machinery, but the upper frequency cut off will limit its usefulness in that application.

WHERE TO START?

- I. **Bad Actors.** Start with the “bad-actors” list. All plants track their worst performing assets to one degree or another. (High maintenance cost and effort, low availability, etc.) The reasons for the poor performance of these assets can be myriad but chances are that one of the reasons they are on the bad actors list is because **not enough information is currently available to diagnose and correct the problems.** Continuous monitoring of vibration and temperature combined with any available process control data can go a long way towards helping the proactive reliability engineer eliminate the sources of a bad actors poor performance.
- II. **Machinery that is dangerous or difficult to access for inspections.** We’ve all seen these poor pumps or motors in the darkened corner of the plant basement. Often leaking, corroded, and installed in poorly lit process areas. Regular inspection routes miss them as their hidden by piping or other equipment. Installing i-ALERT2 devices on these neglected machines helps give them a voice and allows them to communicate potential failures that otherwise would have gone undetected. The same is true of machinery with particularly hazardous operating environments. Collecting data on equipment installed on platforms or in pits can be difficult if not impossible while the equipment is running. Modern machinery guarding can also obscure typical measuring points, and removing it to take a vibration reading typically won’t be allowed. The i-ALERT2 wireless communication enables data collection at a safe proximity from the equipment hazards.
- III. **Equipment that doesn’t run often.** It is difficult and sometimes nearly impossible to try and collect data on a machine that only runs intermittently or at odd hours a hand-held data collector. Batch processes run at all hours of the day or night. Unless someone is assigned to be in front of the machine ready to collect data 24/7, it’s likely you won’t have a great deal of data to analyze should a problem arise.
- IV. **Equipment that has no permanent machinery protection/monitoring system.** Critical assets are sometimes “protected” by permanently installed systems that have the ability to shut down the machinery if it exhibits signs of failure. However these systems are generally very expensive and cannot be applied to all assets in a plant. The low cost and ease of installation of the i-ALERT2 monitor make it a perfect device to bridge the gap between machinery protection systems and periodic inspections. In fact, the i-ALERT2 monitor can completely supplant the use of portable data collectors for monthly inspections. The exception report and alarm / trend information generated by the i-ALERT2 monitor will show a user which machines should be prioritized for further vibration analysis. If a machine generates an alarm or alert, the reliability practitioner can initiate a work order for the in house team or bring in a consultant to perform a diagnostic of the equipment using powerful multichannel vibration analyzers and other advanced instrumentation to investigate the root cause.
- V. **New or Recently Repaired Equipment.** As mentioned earlier in the user guide, the risk of equipment failure due to some defective component or faulty repairs is much more likely to manifest as a failure right at start-up. By installing i-ALERT2 devices on new equipment and recently repaired equipment being commissioned, start-up failures can be reduced, and faulty equipment can be diagnosed right away, protecting the plant from low quality equipment repairs or parts.

CONDITION MONITORING MEASURES

Implementing a condition monitoring technology requires the user to first understand the equipment failure modes and what physical parameters are responsive to changes in the equipment's state. Since not one single device can hope to cover all possible machine configurations or physical measures we will instead offer recommendations for utilizing temperature and casing vibration to detect some of the most common failure modes.

TEMPERATURE

Monitoring and trending the **Temperature** of a bearing housing provides insight into many common problems with rotating machinery such as:

- Inadequate lubrication of rolling element bearings
- Damaged rolling element bearings
- Excessive loading of rolling element bearings
- Inadequate cooling flow from housing fins, jacketed cooling systems or cooling fans
- Excessive ambient or process fluid temperatures

VIBRATION – RMS VELOCITY

Monitoring and trending **RMS velocity** of a bearing housing provides an assessment of how much overall energy is contained in the machines vibration. This can be used to indicate changes to both process conditions and machinery health. Numerous failure modes or machine faults can cause the RMS velocity to increase so an exhaustive discussion of them here is not going to be

attempted. RMS velocity increases can also corroborate a Temperature increase, which assists the reliability practitioner in narrowing down potential failure modes. RMS velocity is by far the most common vibration parameter utilized to gauge overall machine condition.

There are no “absolute” levels of vibration that can be used to indicate if a machine is good or bad. There are too many factors that influence of the overall vibration from one machine to the next. The chart below is provided to assist the user to establishing warning and alarm limits and is taken directly from the ISO 10816 standard. These limits can and should be modified based on the equipment's actual vibration data and user's experience. Remember, a doubling of the overall vibration is almost always related to a change in machine condition.



Figure 9: Example weekly trend data

VIBRATION SEVERITY PER ISO 10816					
Machine		Class I small machines	Class II medium machines	Class III large rigid foundation	Class IV large soft foundation
in/s	mm/s				
Vibration Velocity Vrms	0.01	0.28			
	0.02	0.45			
	0.03	0.71		good	
	0.04	1.12			
	0.07	1.80			
	0.11	2.80		satisfactory	
	0.18	4.50			
	0.28	7.10		unsatisfactory	
	0.44	11.2			
	0.70	18.0			
	0.71	28.0		unacceptable	
	1.10	45.0			

Table 4: Condition based on overall vibration velocity in RMS

KURTOSIS

Monitoring of Kurtosis is a somewhat unique feature in condition monitoring equipment that separates the i-ALERT2 monitor from traditional overall vibration meters. Kurtosis is a mathematical function that indicates how “peaky” a data set is. It is related to Crest Factor which is another commonly used vibration parameter used to assess machine condition. Kurtosis will tend to increase in the event the machinery starts to experience increases in Impacting and is relatively insensitive to changes in speed or load. Impacting can come from many sources such as bearing faults, cavitation, or mechanical looseness. It is recommended that the user first establish baseline levels of Kurtosis and then adjust warning/alarm limits accordingly as some machinery will naturally have widely varying levels of Kurtosis in their vibration data sets. Kurtosis values around 3 are considered “Normal.”

Kurtosis is subject to the same limitations as Crest Factor when determining bearing failure progression. If there is no significant impacting such as with long shallow spalls in a bearings race or inadequate lubrication the Kurtosis measure will not change significantly.

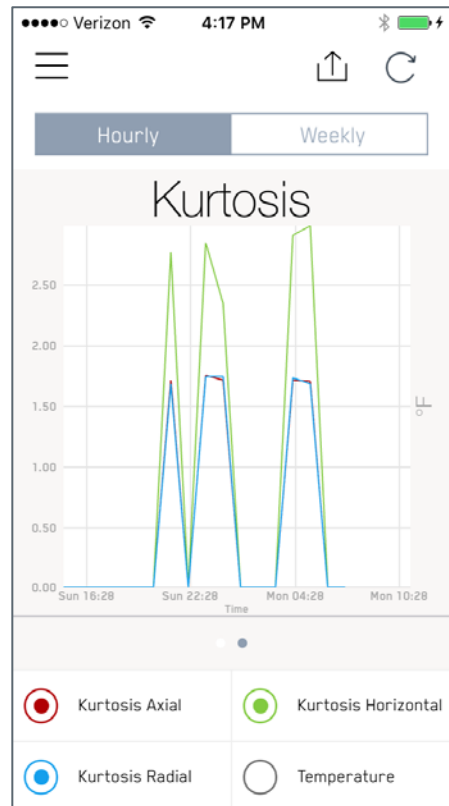

Figure 10: Trend of Kurtosis

INSTALLATION BEST PRACTICES

MOUNTING LOCATIONS

GENERAL GUIDELINES

In general the ideal place to mount the i-ALERT2 device is as close as possible to the machines bearings in a place where the LEDs can be easily observed. Since the primary function of the i-ALERT2 device is to monitor for changes in condition, it is not critical that the device be placed in the “load zone” of the bearing. Doing so may give a more accurate amplitude reading, but may obscure the LEDs which are used for local status indication.

In general, a standard machine train consisting of a driver and driven piece of equipment can be monitored by 2 i-ALERT2 devices. Up to 4 monitors can be installed per machine train, one at each bearing if necessary.

Machine Type	Non-Drive End Bearing	Drive End Bearing	Drive End Bearing	Non-Drive End Bearing
Driver	Optional	Recommended		
Driven Machine			Recommended	Optional

Figure 11: Recommended monitoring points

I-FRAME PUMP

On any ITT Goulds Pumps that come equipped with the i-ALERT2 device, a slot will be machined in the bearing housing to mount the device within close proximity to both bearings. See figure 12.

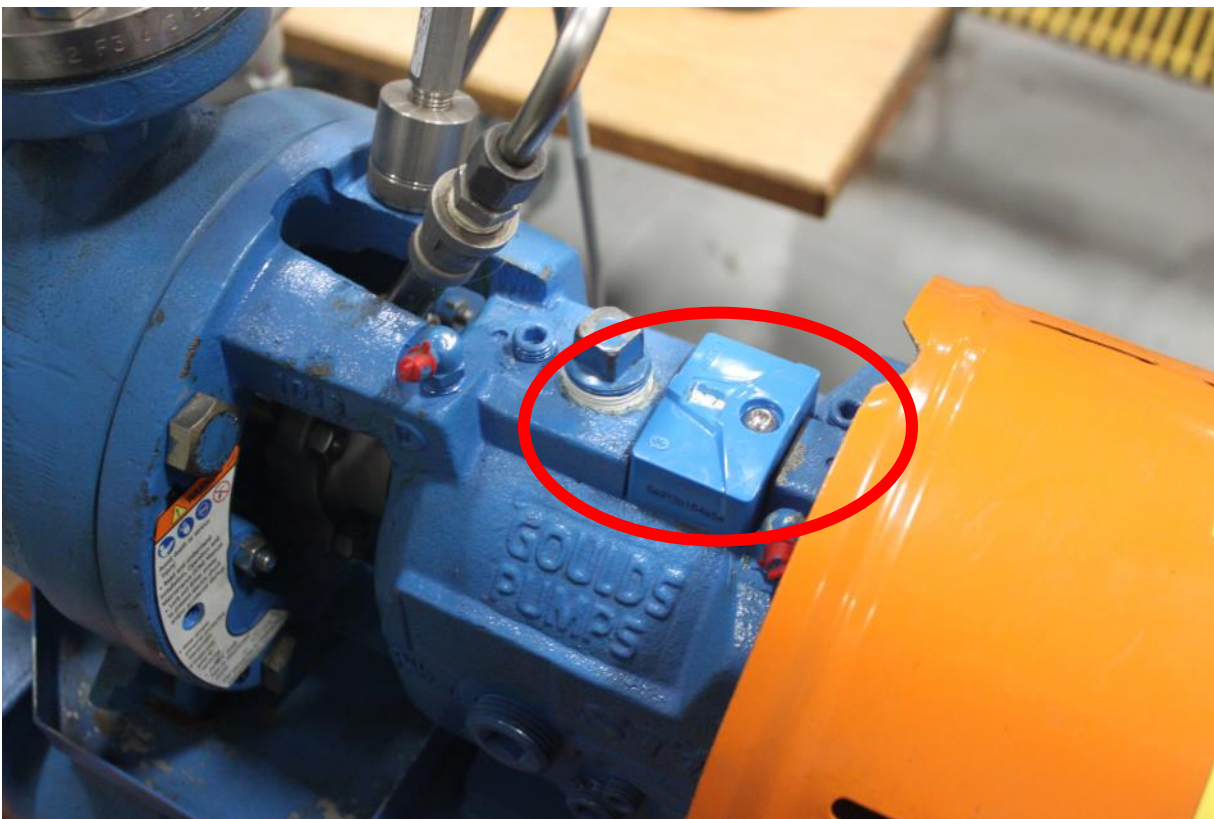

Figure 12: ITT Goulds 3196 i-FRAME contains milled slot for mounting the monitor

END SUCTION PUMP

On end-suction (overhung) style pumps where the thrust and radial bearings are contained within the same bearing housing, ITT Goulds Pumps recommends mounting the i-ALERT2 device centrally on the bearing housing in an area where the LEDs can easily be observed.

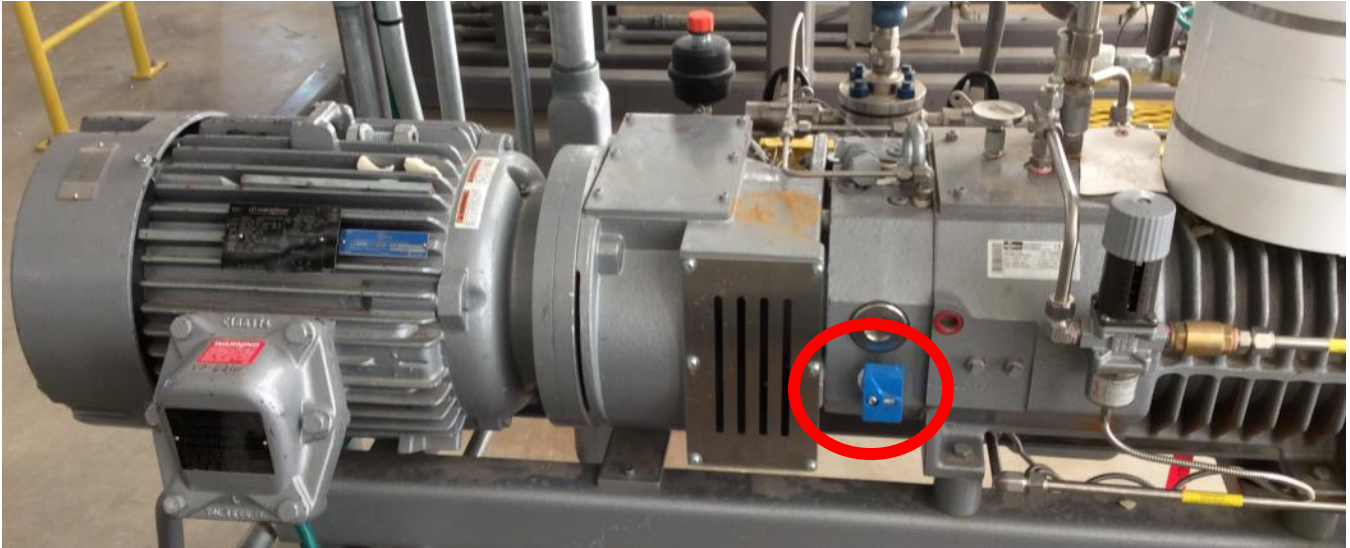

Figure 13: PD pump, side mounted to frame

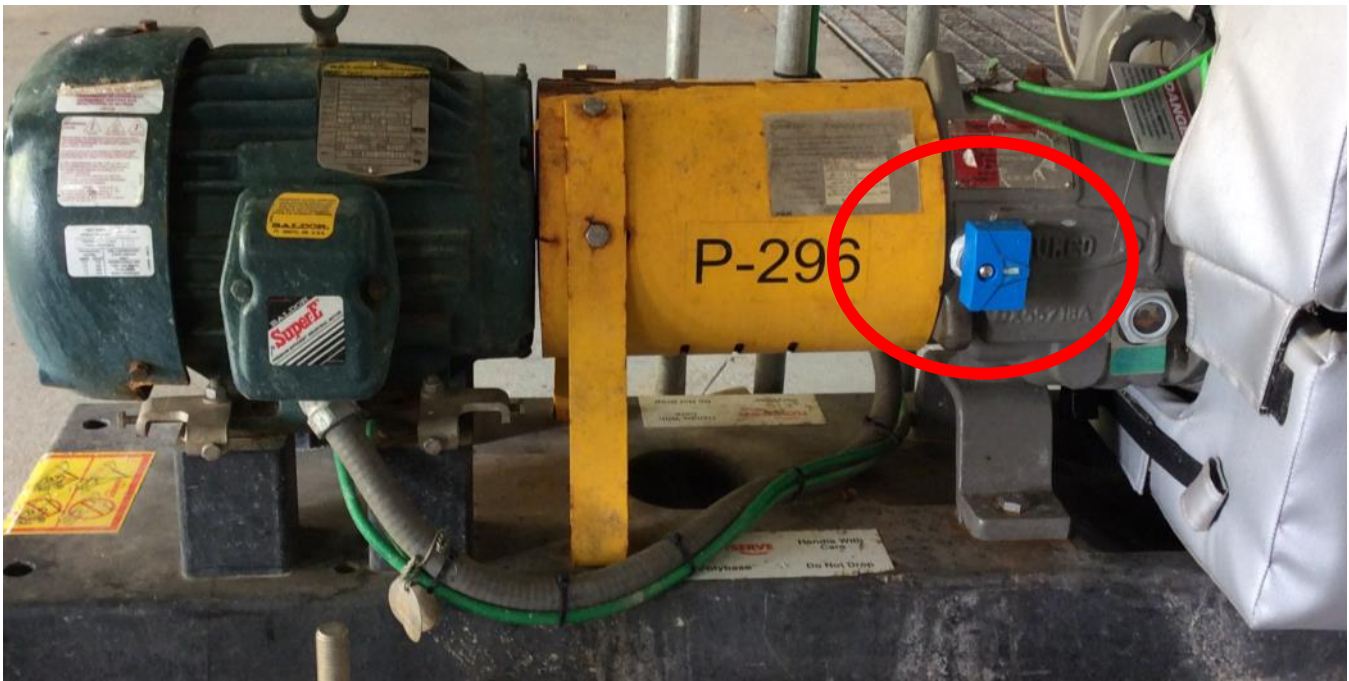

Figure 14: Chemical Process pump, side mounted to bearing frame

HORIZONTAL ELECTRIC MOTORS

Mount the i-ALERT2 monitor directly over the bearing housing on the drive-end bearing. A second monitor can be mounted over the non-drive end bearing if desired. Never mount a monitor on a fan cover!



Figure 15: Horizontal motor, mounted over drive end bearing housing

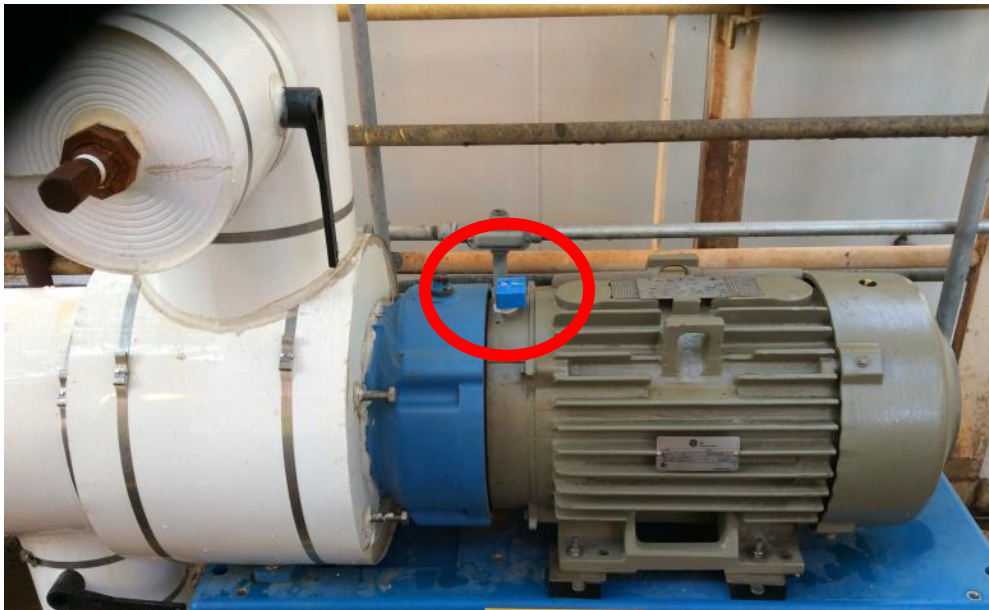

Figure 16: Close coupled motor, mounted over drive end bearing housing

BETWEEN BEARINGS PUMP

On between bearings pumps, it is recommended to mount i-ALERT2 monitors to both bearing housings. If only one device is to be installed on a pump, then it should be installed on the bearing housing that contains the thrust bearing. Note, that this is not always the drive end bearing housing. Be sure to check the pumps cross sectional drawing to verify location of the thrust bearing.



Figure 17: Between Bearings Pump (BB3), mounted on each bearing housing



Figure 18: Double Suction , Horizontal Split case pump, mounted on thrust bearing housing

VERTICAL ELECTRIC MOTORS

The best mounting location for the i-ALERT2 device will depend on which class of vertical motor is being monitored. For vertical solid shaft motors with 2 rigid bearings, instrument the upper thrust bearing housing first since this is the primary bearing absorbing thrust loads. The lower bearing can also be instrumented if desired.

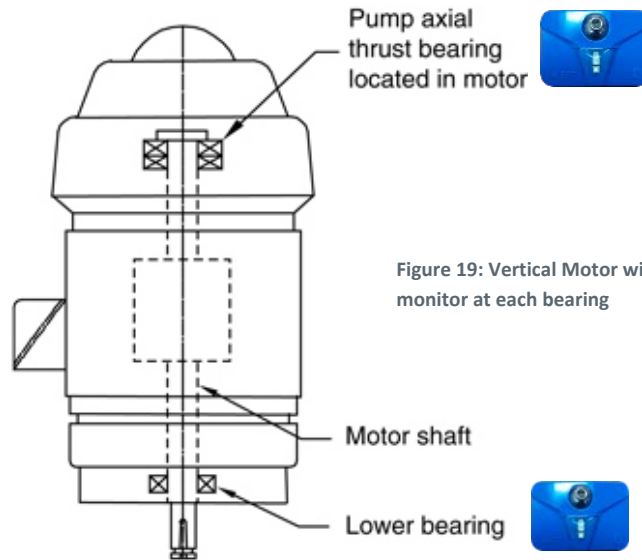

Figure 19: Vertical Motor with 2 Bearings, monitor at each bearing

For vertical hollow shaft (VHS) motors it is recommended to mount the i-ALERT2 device adjacent to the thrust bearing at the top of the motor. Most VHS motors do not have lower bearings and therefore there is no need for a second monitor.

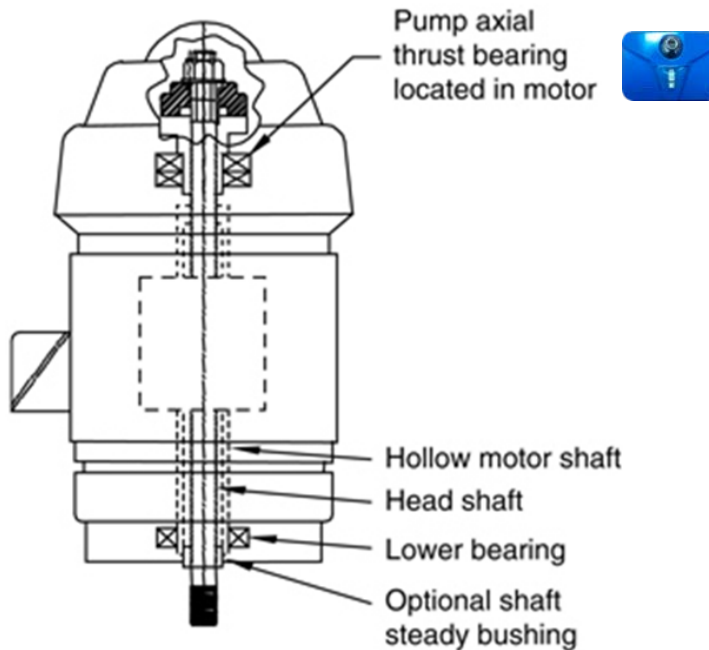

Figure 20: Vertical Hollow Shaft Motor, at thrust bearing

VERTICAL PUMP

Vertical pumps can be instrumented with the i-ALERT2 device at the pump discharge head. See image below. Mount the device at the top of the discharge head where the LEDs are clearly visible.

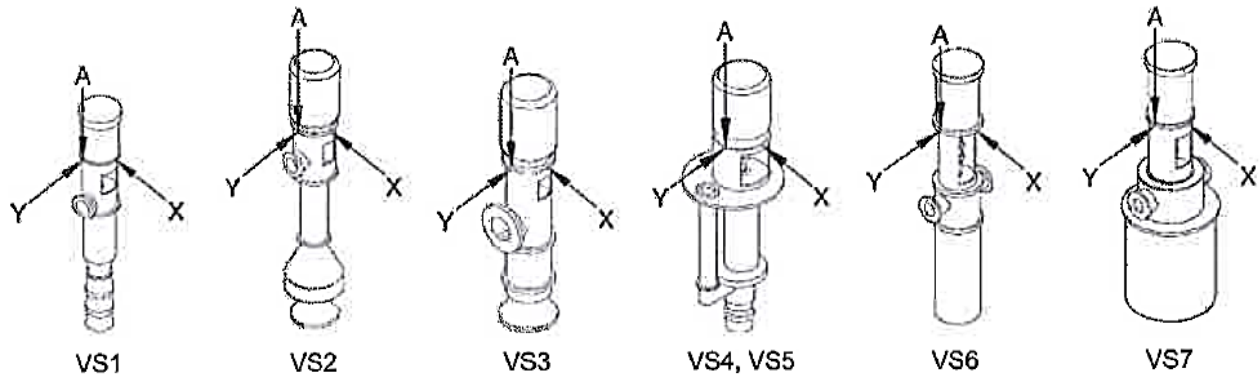

Figure 21: Arrows show recommended mounting location for vertical pumps (On Discharge Head)

MIXERS

Mixer configurations can vary widely so ITT does not recommend any single best location. Use good engineering judgment and knowledge of the machine design to appropriately locate the monitor. Nearer to the bearings and sources of potential vibration energy is best.

VACUUM PUMPS

ITT recommends monitoring the drive end bearing housing for vacuum pumps.



Figure 22: Vacuum Pump, side mounted to bearing housing

MOUNTING METHODS

There are three methods that can be used to mount the i-ALERT2 device to a machine. They are shown in the figure below. On new pumps and pumps repaired through ITT PRO Services, a slot will be milled into an appropriate location on the bearing housing and the device will be secured with a screw. Alternatively, a hole can be drilled and tapped and a small adapter plate can then be used to secure the device. Lastly, the device can be epoxied directly the machine via the mounting plate. Make sure to use a good quality, rigid epoxy. Do not use RTV or Silicon to mount the device.

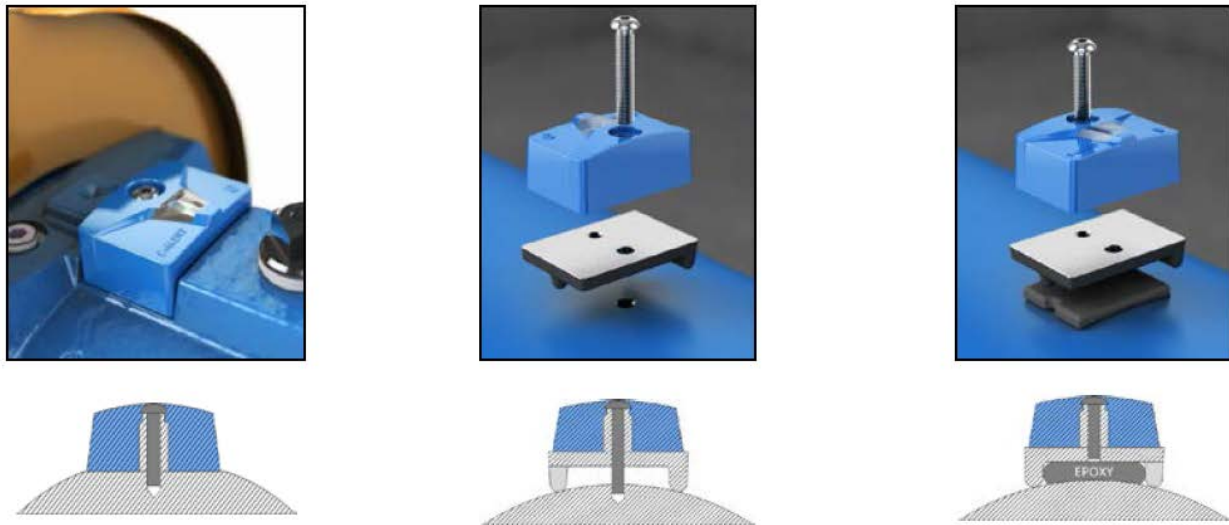

Figure 23: Mounting Methods

CAUTION:

Always wear protective gloves. The equipment and the i-ALERT2 device can be hot.

Mill a Slot	Drill and Tap	Epoxy
Screw: ¼-28 x 1.125in	Screw: ¼-28 x 1.5in	Screw: ¼-28 x 1.125in
Slot: 2.25in L x 1.6in W	Tap: ¼-28 UNF x ¼in deep	Epoxy: application specific

COMMISSIONING

STEPS TO ACTIVATE THE I-ALERT2 EQUIPMENT HEALTH MONITOR:

1. Remove the sticker.
2. The i-ALERT2 device will look for light. Note: If in a dark environment use light source to activate.
3. When activated a sequence of flashing LEDs will start to indicate that the unit is powered on.
4. When sequence is completed the green LED will flash every 5 sec under normal operating conditions



TO RESET THE I-ALERT2:



Action	LED	Action performed if magnet is removed	System Action performed if magnet is removed
Apply Magnet over Bluetooth Symbol For 1 second	Red LED active	Red LED active	Nothing
Magnet held in place for additional 2 seconds.	Blue LED active	Red LED Flash: Bluetooth OFF Green LED Flash: Bluetooth ON	Bluetooth radio On/Off toggle
Magnet held in place for additional 4 seconds	LEDs cycle through all colors	All Three LEDs will Flash and turn OFF	Unit RESETS when LEDs stop Flashing

Figure 24: Using a magnet to reset an i-ALERT2

I-ALERT2 EQUIPMENT HEALTH MONITOR ROUTINE OPERATION

Measurement interval

The measurement interval for the condition monitor during normal and alarm operation is 5 minutes.

When the monitor measures a reading beyond the specified temperature and vibration limits, the appropriate red LED flashes (after 2 consecutive readings). After the process or pump condition that causes the alarm is corrected, the condition monitor returns to normal mode after one normal-level measurement.

Alarm mode

The condition monitor's alarm mode is activated after two consecutive readings. When the alarm mode is on, you should investigate the cause of the condition and make necessary corrections in a timely manner.

Magnetic device considerations

Be careful when you use magnetic devices in close proximity of the condition monitor, such as magnetic vibration-monitoring probes or dial indicators. These magnetic devices can accidentally activate or deactivate the condition monitor resulting in improper alarm levels or loss of monitoring.

Wireless Integration

A Bluetooth Low Energy Radio is utilized to communicate condition monitoring information to a mobile Smart device that the operator can easily view and react to.

I-ALERT2 EQUIPMENT HEALTH MONITOR TROUBLESHOOTING

Symptom	Cause	Remedy
There are no red, green, or blue flashing LED	The battery is dead.	Replace the equipment health monitor.
	The unit is in sleep mode.	Activate the condition monitor using magnet.
	The unit is malfunctioning.	Consult your ITT representative for a warranty replacement.
The red LED is flashing, but the temperature and vibration are at acceptable levels.	The baseline is too low.	Check the temperature and vibration levels and request new baseline. Or manually change alarm limits.
	The unit is malfunctioning.	Consult your ITT representative for a warranty replacement.

Figure 25: Troubleshooting

I-ALERT2[®] MOBILE APP OPERATION

INSTALLING THE APP

To download the app to your mobile device you must navigate to the Apple App Store or Google Play application on your mobile device and search for “i-ALERT2”. The App icon should match the one shown below. Note that your device must be compliant with Bluetooth Smart / 4.0 for the App to function properly.



Once you have downloaded and installed the app, you will need to register with a valid email address in order to log in. Many helpful videos are also available at <http://ittproservices.com/aftermarket-products/monitoring/i-ALERT2-condition-monitor/i-ALERT2-app-videos/>.

CONNECTING TO I-ALERT2 DEVICES

Upon gaining access to the app you will be brought to the “Scan for Devices” page, see Figure 26 below. This page will display any i-ALERT2 devices within range of your mobile device. Devices that are in range will have a green icon to the left of them. Click on the devices name to connect to it. (You can reach the scan for devices option at any time by tapping icon in the upper left hand corner to bring up the main menu options.

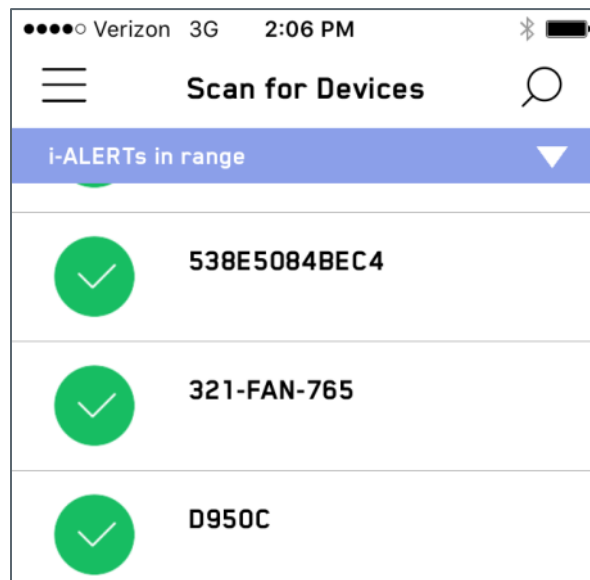

Figure 26: Scan for devices

Devices that are no longer in range will have a grey icon next to their names. See Figure 27.

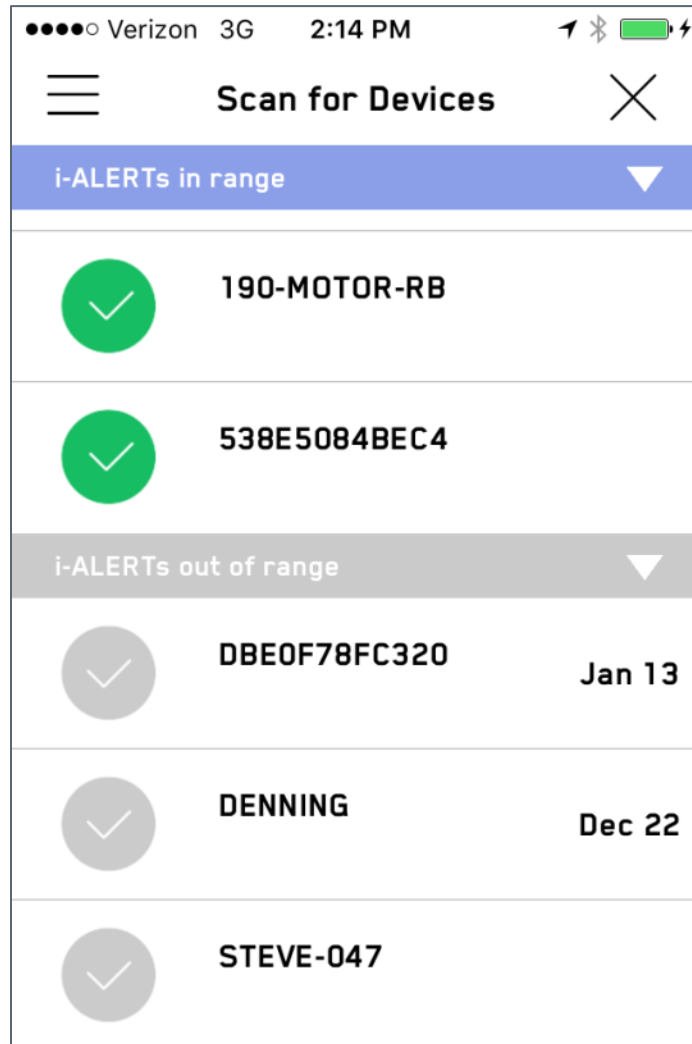

Figure 27: Devices in range and out of range

After clicking on the device's name, the screen shown in figure 28 will come up as the phone and i-ALERT2 device begin to communicate. Once all 4 steps are completed and green checkmarks are shown you will be taken to the device dashboard showing the latest data.

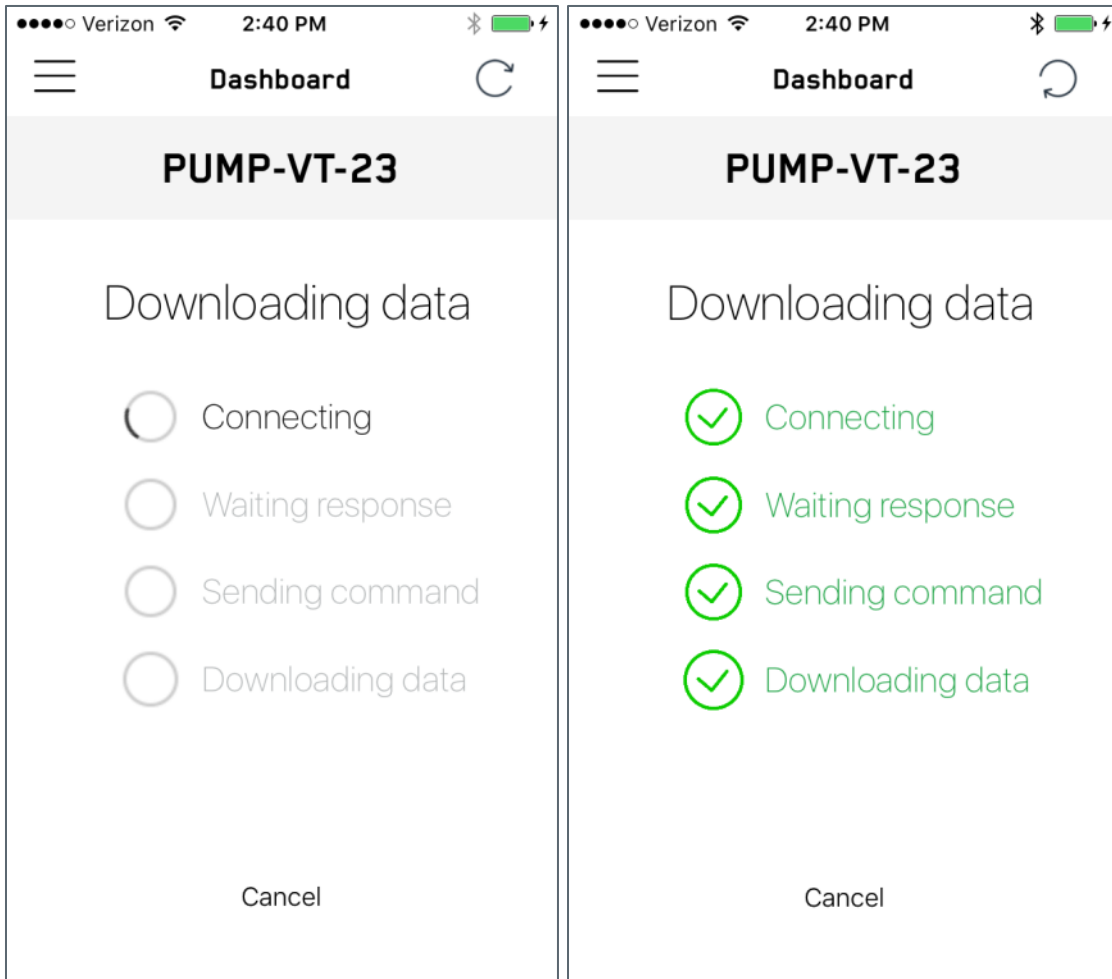

Figure 28: Connecting

DASHBOARD

The Dashboard page (Figure 29) shows the latest overall vibration amplitudes and temperature measurements as well as the total Runtime hours and Battery Status. To refresh the dashboard and request the latest reading, tap the circular arrow icon on the top right hand portion of the screen.

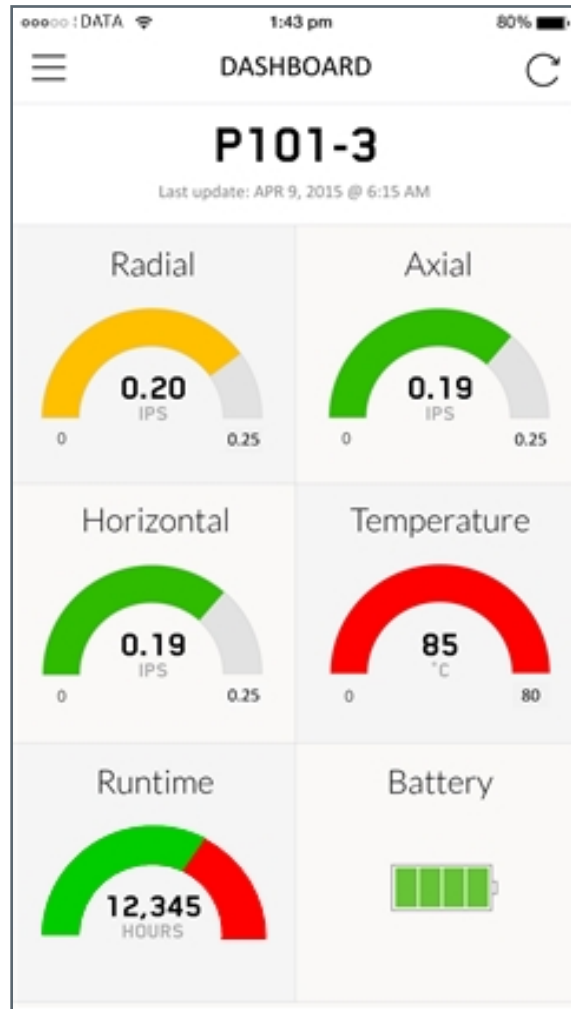

Figure 29: Dashboard

TRENDING

Tap on any of the individual measurement icons on the Dashboard page to bring up the Trend page. Alternatively, you can tap the icon in the top left corner that looks like 3 horizontal lines and select “Trending” from the drop list. (Figure 30)

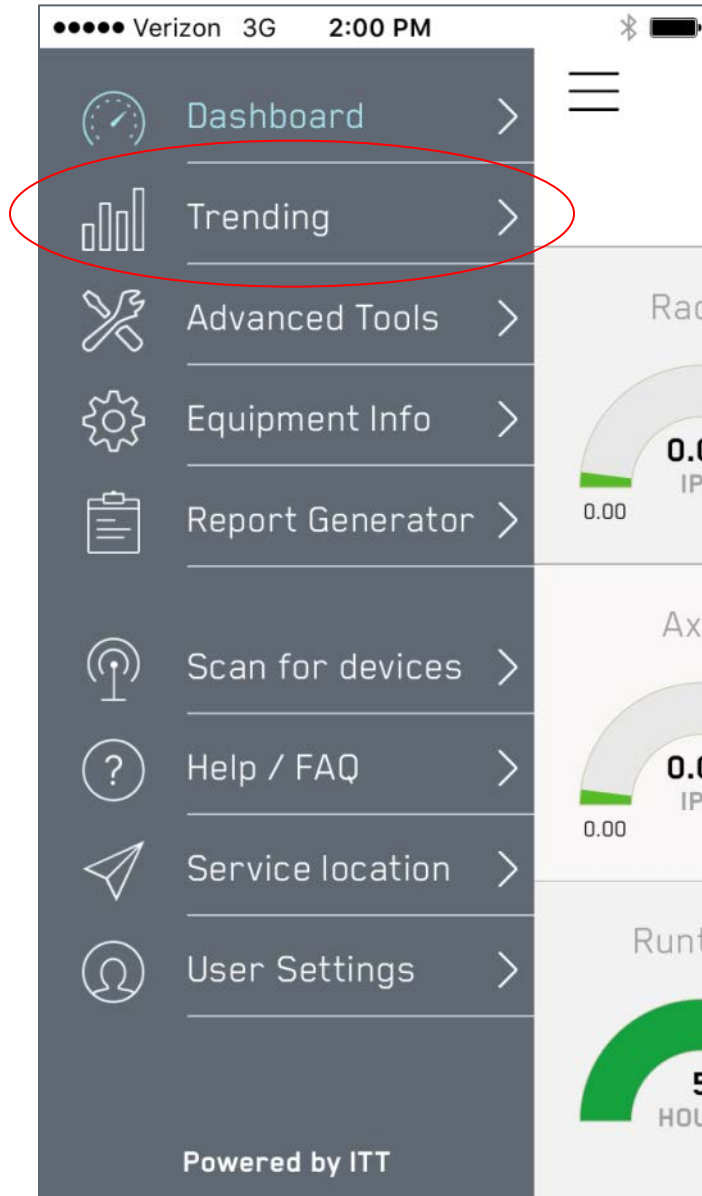

Figure 30: Trending

The Trend page shows the historical values of each individual measurement. You can overlay or remove measurement trends by clicking the radio buttons on the bottom of the screen. See Figure 31.

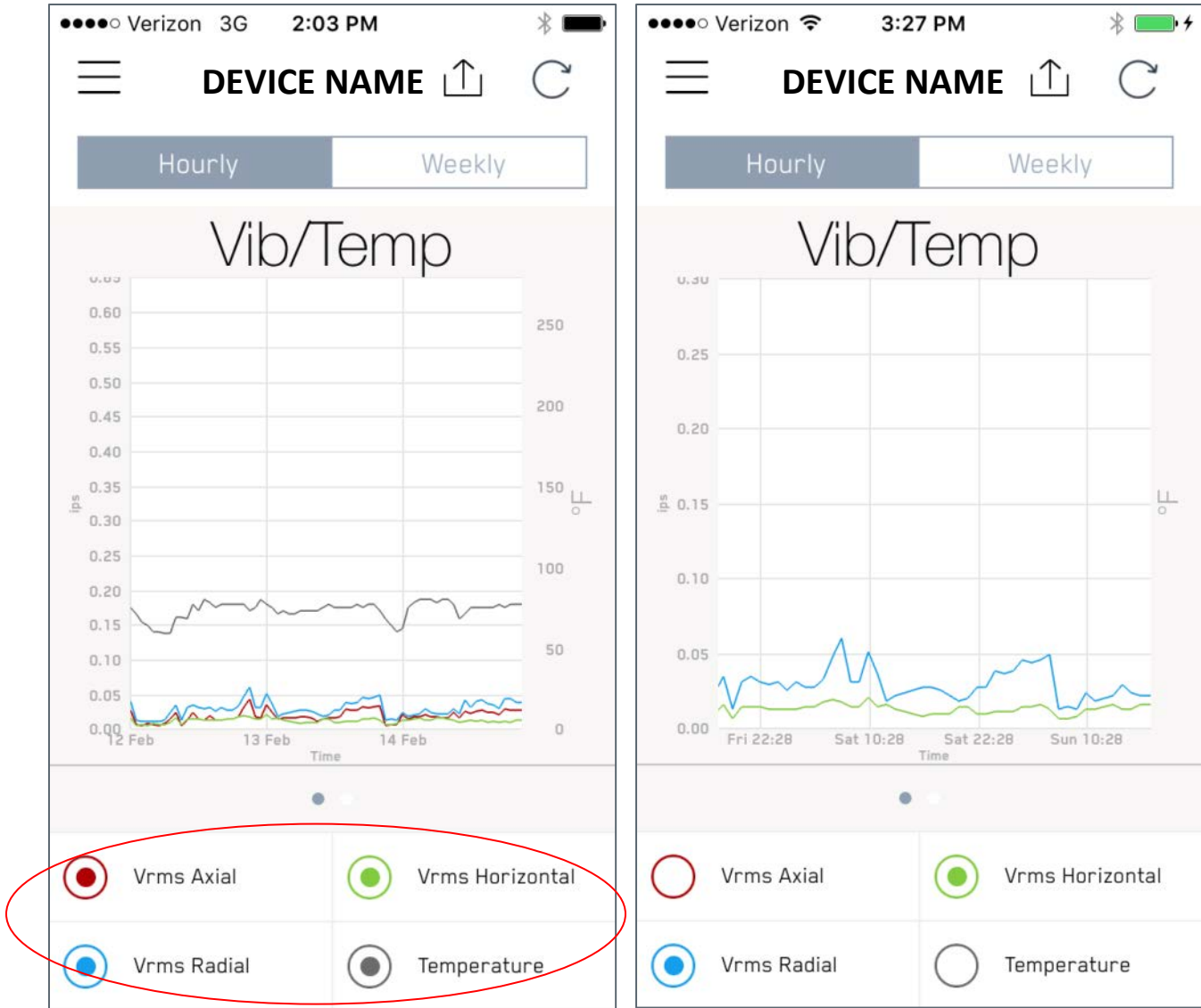

Figure 31: Default Trend view on left, Trend view with several measurement de-selected shown on the right.

To change the trend chart to show a longer time frame, tap the “Weekly” button above the chart. This will change the chart to display the last 4 weeks of trend data. To view the numerical values instead of the graphical trend, tap the icon that looks like an arrow pointing up next to the devices name. See figure 32. To return to the graphical trend, click the “DONE” button at the top left.

If you would like to export the numerical data click on the up arrow icon at the bottom left of the page. (Note: the upload icon may not always be at the bottom left, in some cases it is at the upper right. Regardless of location the function remains the same.) See figure 32. You will have a choice to print it directly to a local printer, or attach it to an email in the CSV file format. CSV files are universal and can be imported to plant historians or opened with a spreadsheet processing program.

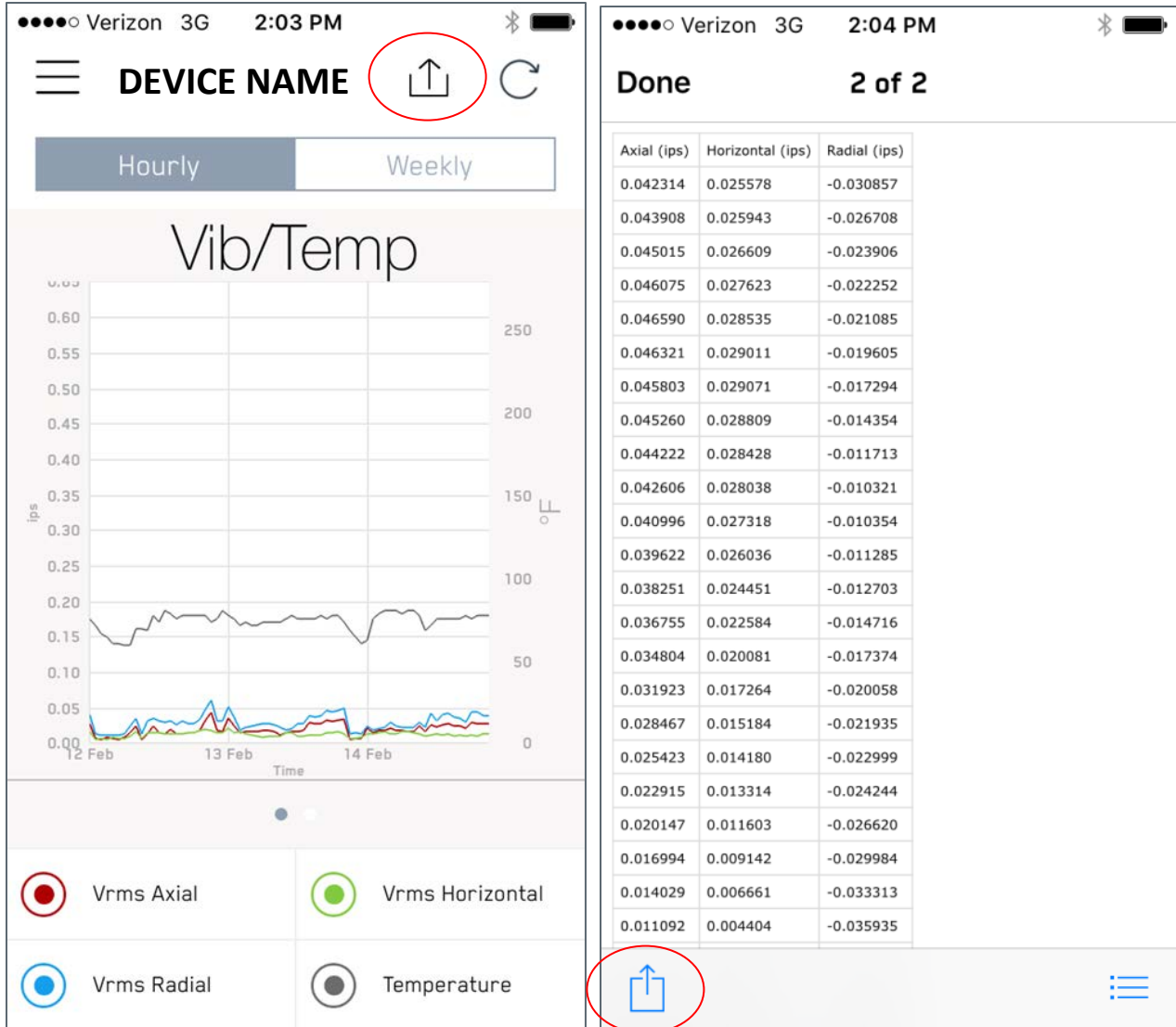

Figure 32: Tap the upward facing arrow to view numerical data, tap the icon again on the subsequent page to export the data

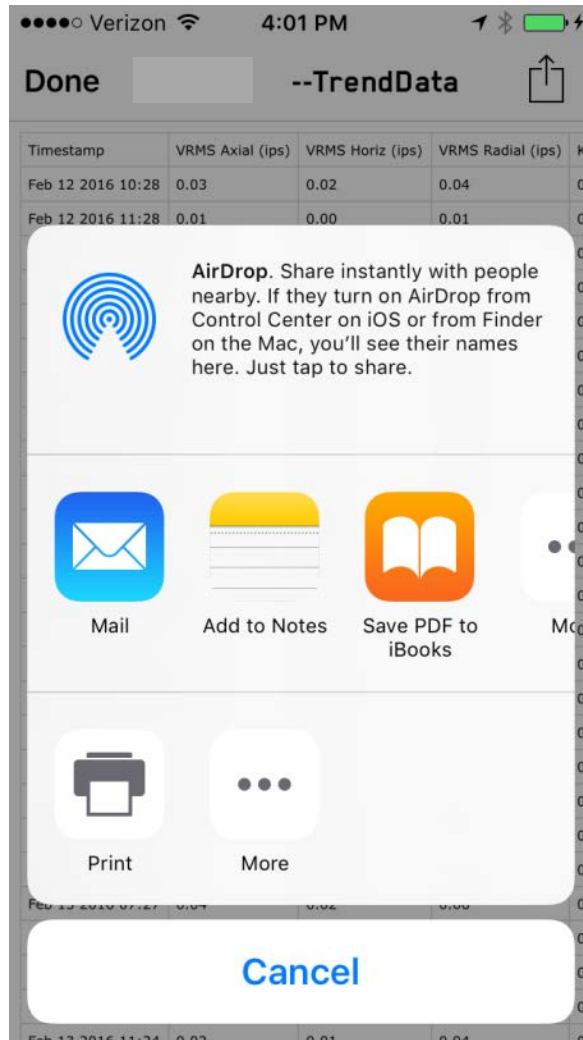

Figure 33: Export trend data by printing or attaching to email

The trend data may be difficult to see in the default window. Fortunately, you can zoom in and out as well as pan right or left using standard mobile touchscreen commands. To pan, simply swipe right or left to move the chart. To Zoom In, touch the trend chart with 2 fingers and spread them apart. You can use this gesture to change both the X and Y scales on the chart. You can also Zoom in on a specific area of the graph by double tapping. To Zoom Out, touch the screen with pinch your fingers together. To reset the zoom to the default setting, you will have to leave this screen by either going into the Kurtosis trend or switching to “Weekly” and back.

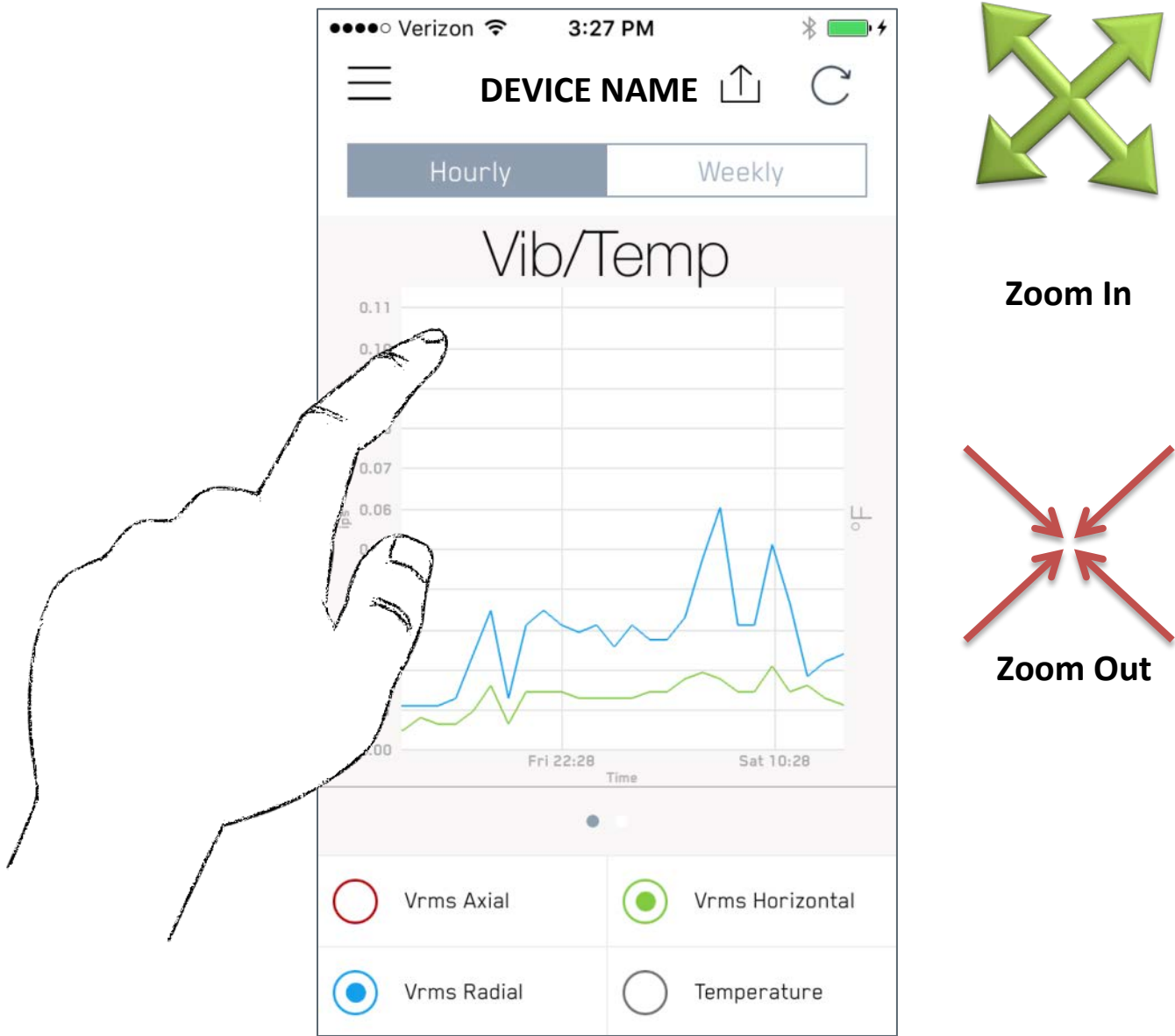

Figure 34: Trend graph zoomed in

WEEKLY VIEW

The weekly view option in the trend will look slightly different than the Hourly view. You will notice there is still the Trend line showing the Average value but there is also a colored region accompanying the trend. The colored region shows the maximum and minimum values measured during that time period. (Note that non run hours are dropped from the average measurement calculation)

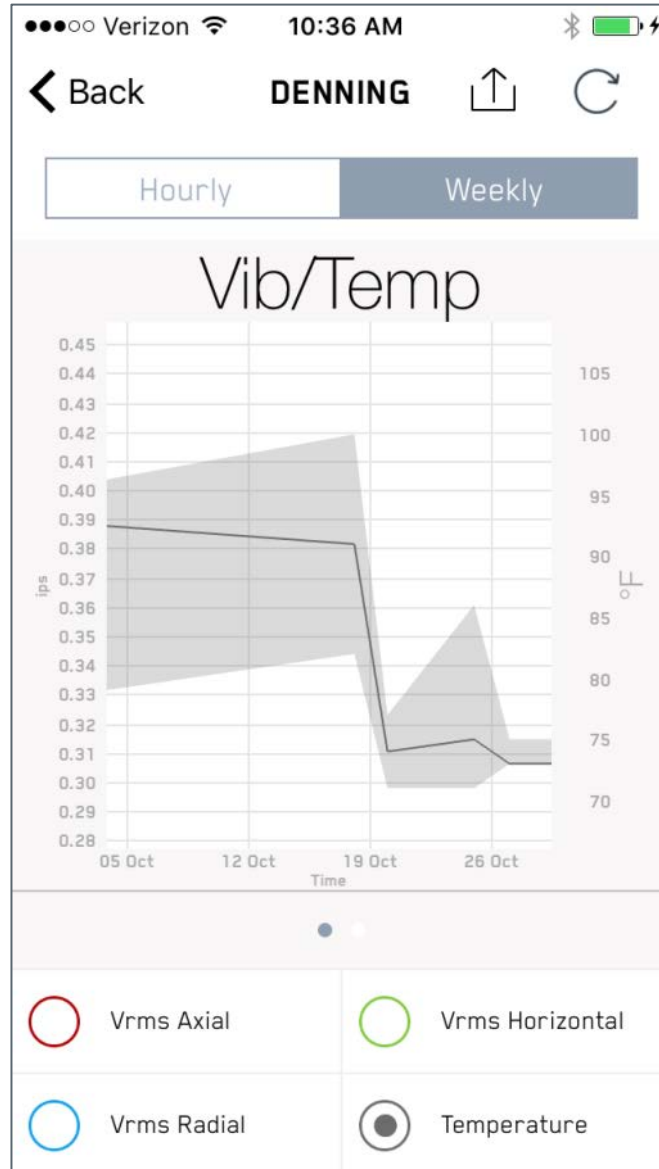

Figure 35: Export trend data by printing or attaching to email

KURTOSIS

Kurtosis is a measure of how “peaky” a data set is. (i.e. The many vibration data points recorded by the i-ALERT2 monitor for a given sensor axis would constitute a data set) Higher values of kurtosis generally indicate increased crest factor of the vibration signal. The crest factor is the ratio of the peak to standard deviation. Kurtosis is used for fault detection in machinery, although it does not indicate the specific cause. Higher values indicate progressive states of fault progression.

ITT suggests utilizing Kurtosis to gauge machine condition in the same way the overall vibration amplitudes are used. As the value trends up, it means that the machinery is spending more time vibrating at higher peak amplitudes, even though the RMS (overall) value remains unchanged. This allows for earlier detection of faults.

To access the Kurtosis Trend, tap the small grey dot just below the trend graph. See figure 36. The Kurtosis value of the temperature trend is likely to be very low and will skew the graph. Remove the temperature trend and zoom in to better view the Kurtosis Trend values of each vibration axis sensor. To return to the Overall Vibration Trend, tap the small grey button under the graph.

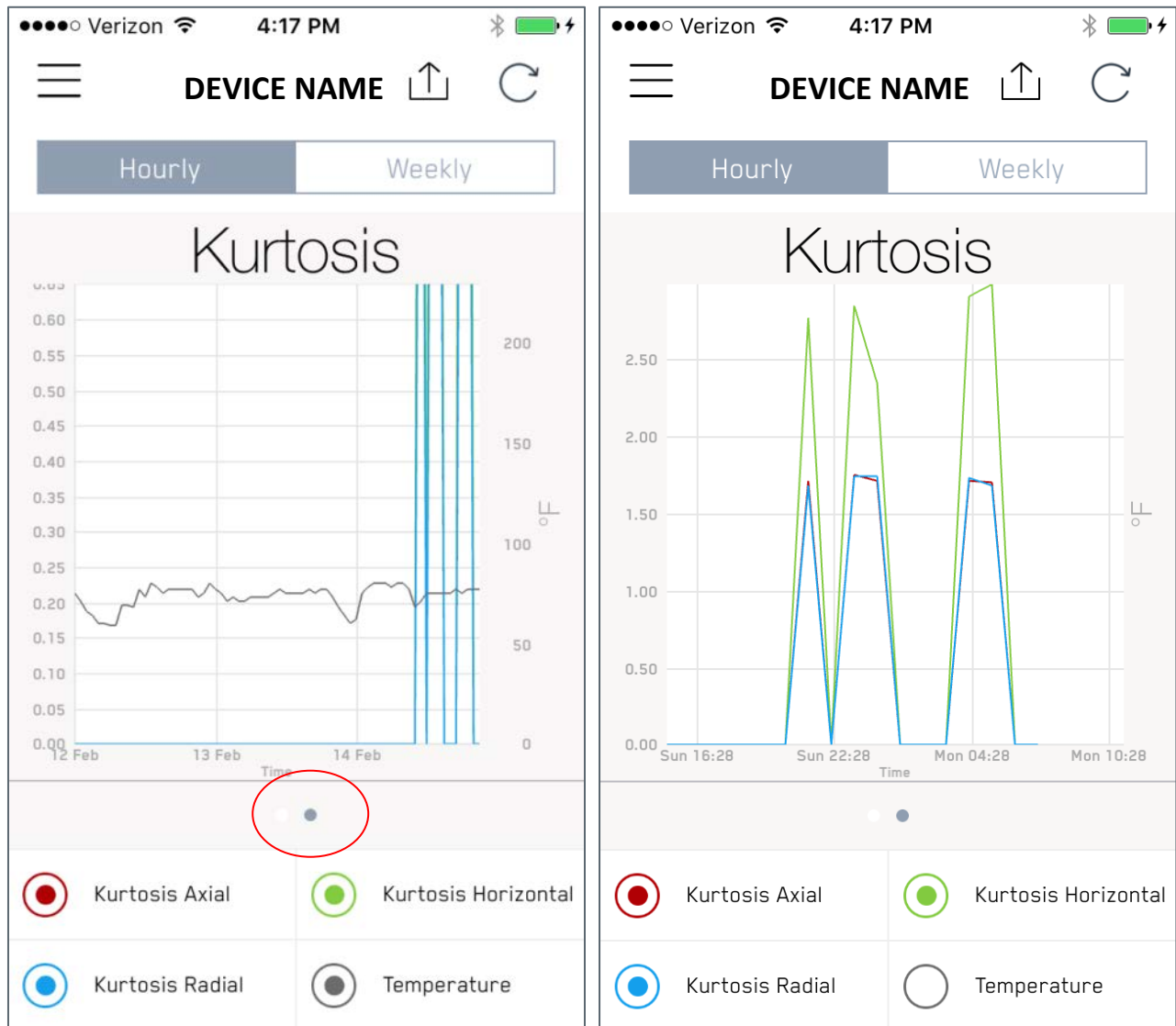

Figure36: Tap the small grey button under the Trend to display Kurtosis, Kurtosis Trend with Temperature removed on right

ADVANCED TOOLS

The i-ALERT2 device offers some advanced tools that can help in troubleshooting equipment. To access these tools, tap the icon in the upper left that looks like 3 horizontal lines again and then tap “Advanced Tools”. See figure 37.

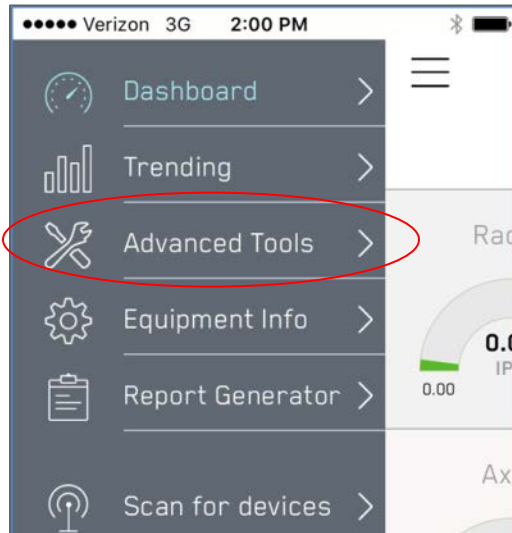

Figure 37: Advanced Tools enables diagnostics

The Advanced Tools page will immediately open up to a new page showing that latest spectral or Fast Fourier Transform (FFT) and time waveform (TWF) data captured on the Radial sensor axis. See figure 38.

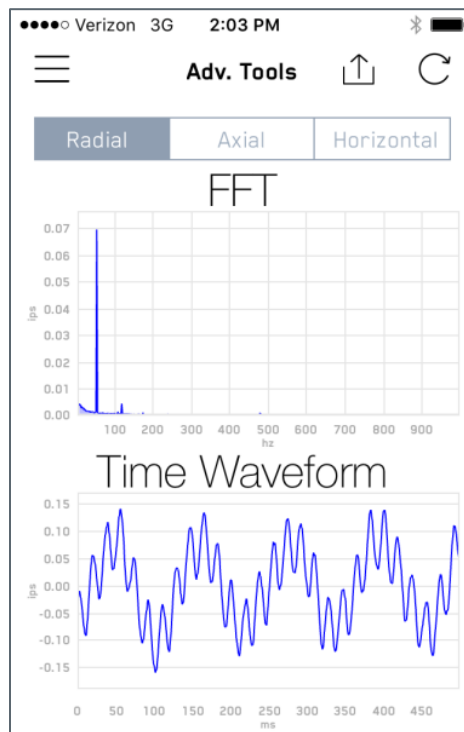

Figure 38: FFT and TWF

FFT AND TWF DATA

The FFT graph and TWF can be zoomed in or out using the same touchscreen commands as described in the “Trending” section. To display the latest dataset from each different sensor axis, simply tap the “Axial” or “Horizontal” buttons at the top of the spectrum. See figure 39. To request an updated FFT/TWF, tap the refresh (circular arrow) at the top right of the page. This will bring up a new menu with several options to choose from.



Figure 39: Switch between sensor axes or request updated dataset

STORED AND ALARM GENERATED FFT DATA

You can access stored datasets including those stored when an alarm is triggered. This is a powerful feature that can assist in resolving difficult or intermittent problems that would typically be missed with traditional walk around periodic vibration monitoring, to access historical FFT and TWF data sets, simply tap the circular arrow icon at the top right of the page while viewing any sensor's FFT data in the Advanced Tools menu. A message will appear asking you what particular datasets you would like to view or if you would like to request a new FFT. See figure 40.



Figure 40: Request new FFT or access stored FFT datasets

EQUIPMENT INFORMATION

One of the most useful features of the i-ALERT2 mobile app is the ability to instantly access equipment details. The “Equipment Information” page also includes functionality that allows a user to adjust alarm and warning limits as well as send commands to the i-ALERT2 monitor to reset the device. To access the Equipment information page, tap the icon in the upper left that looks like three horizontal lines and then choose “Equipment Info.” See figure 41.

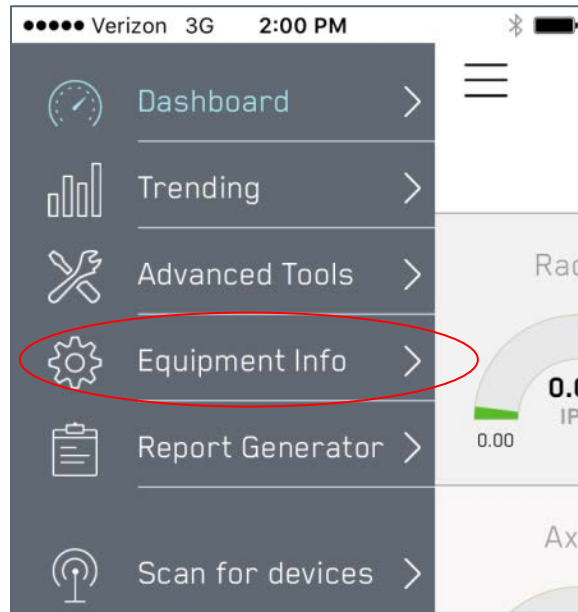

Figure 41: Equipment information

ALARMS / WARNINGS

To view and change the Alarm/Warning limits in the i-ALERT2 monitor, tap the “Alarms / Warnings” tag. See figure 24.

The “Alarm Settings” page will be displayed. (figure 42) From here a user can adjust the overall vibration amplitudes and temperatures that cause the device to go into alarm or warning modes. Tap the “+” or “-” icons at the right hand side to adjust values.

After updating the alarm or warning settings, they must then be sent down to the i-ALERT2 device in order to be programmed in. To do this, tap the “Send” button at the top right. (Figure 43).

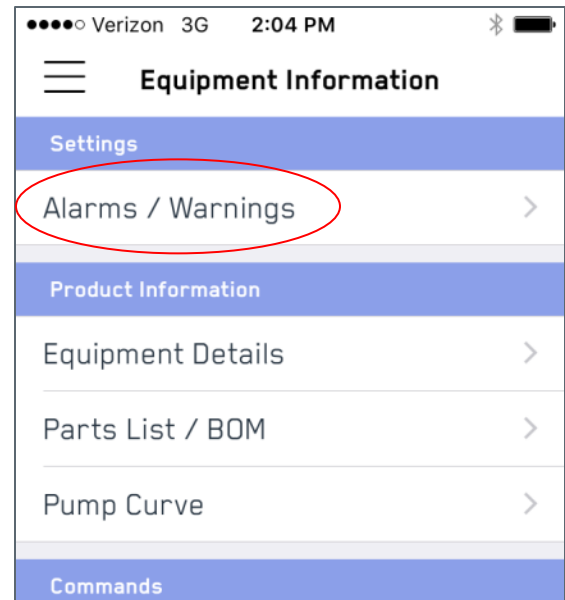

Figure 42: Alarms/Warnings

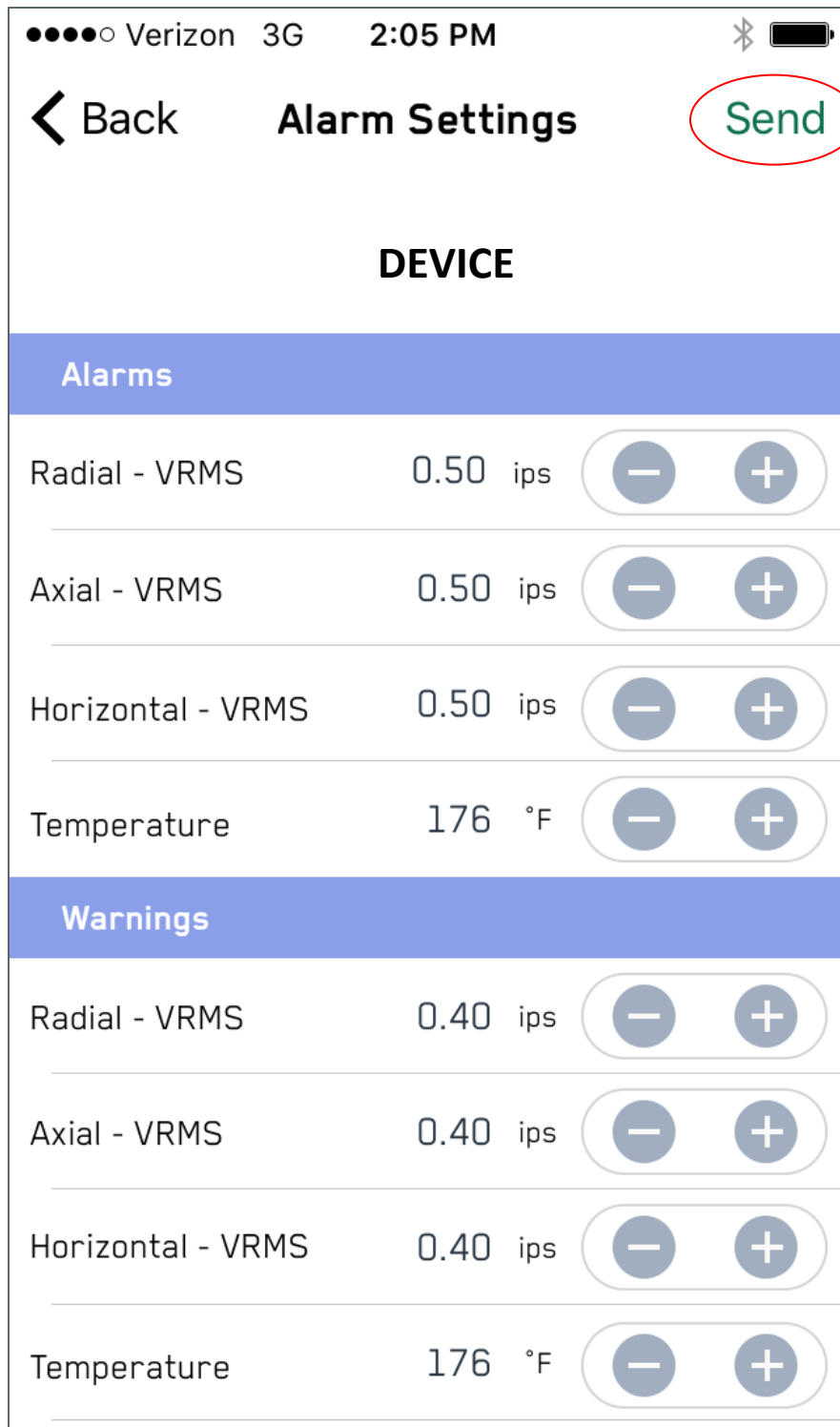

Figure 43: Use the + and – buttons to adjust values. Tap “Send” to program the new device settings.

EQUIPMENT DETAILS

The “Equipment Details” page allows the user to view and change fields that relate to the machine configuration as well as the internal components. You’ll also note that this menu allows you to change between the “Current” configuration and the “As Built” information, which allows a user to update the equipment information but keep the original data. See Figure 44.

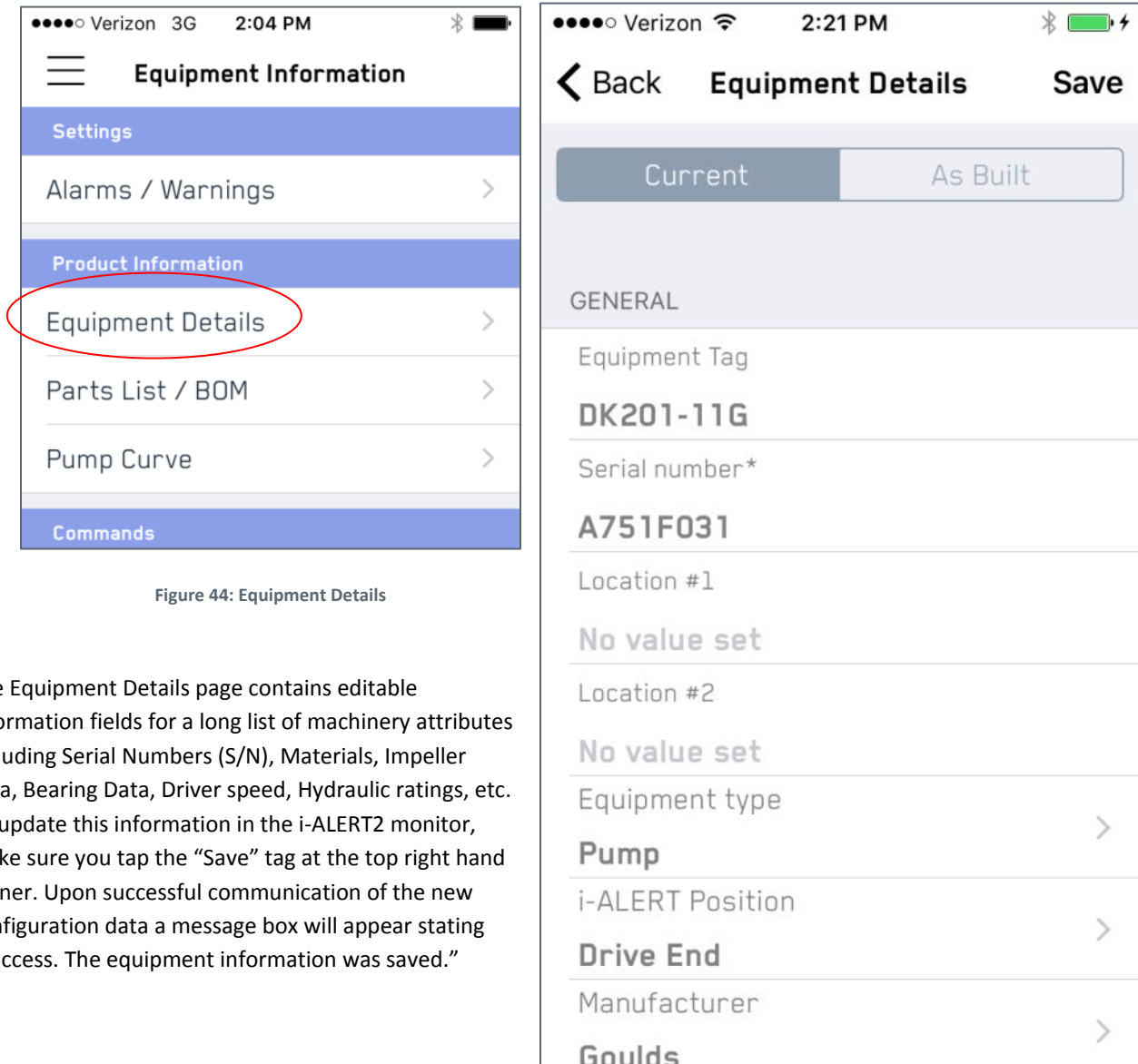

Figure 44: Equipment Details

The Equipment Details page contains editable information fields for a long list of machinery attributes including Serial Numbers (S/N), Materials, Impeller data, Bearing Data, Driver speed, Hydraulic ratings, etc. To update this information in the i-ALERT2 monitor, make sure you tap the “Save” tag at the top right hand corner. Upon successful communication of the new configuration data a message box will appear stating “Success. The equipment information was saved.”

Figure 45: Entering a Goulds S/N enables additional functions

Note: Once a valid ITT Goulds Pumps S/N is entered into the “Equipment Details” page, there is no need to manually enter any other data. The next time it connects to the internet the mobile app will communicate with the ITT servers and pull down this information, auto-populating it within the app.

PARTS LIST / BOM

The "Parts List / BOM" is not user editable and only applies to ITT Goulds Pumps products. If a valid ITT Goulds Pumps S/N is entered into the Equipment Details page the user should be able to view all the parts on the bill of material. The user can also choose to send part information via email to their purchasing department or local ITT Goulds Pumps sales representative. To Send parts information via email (Email must be configured on the mobile device), simply tap each part that you need and then tap the upwards arrow icon in the upper right portion of the screen. This will open your mobile devices email application and insert the requested parts as text in the body of an email. See Figure 46.

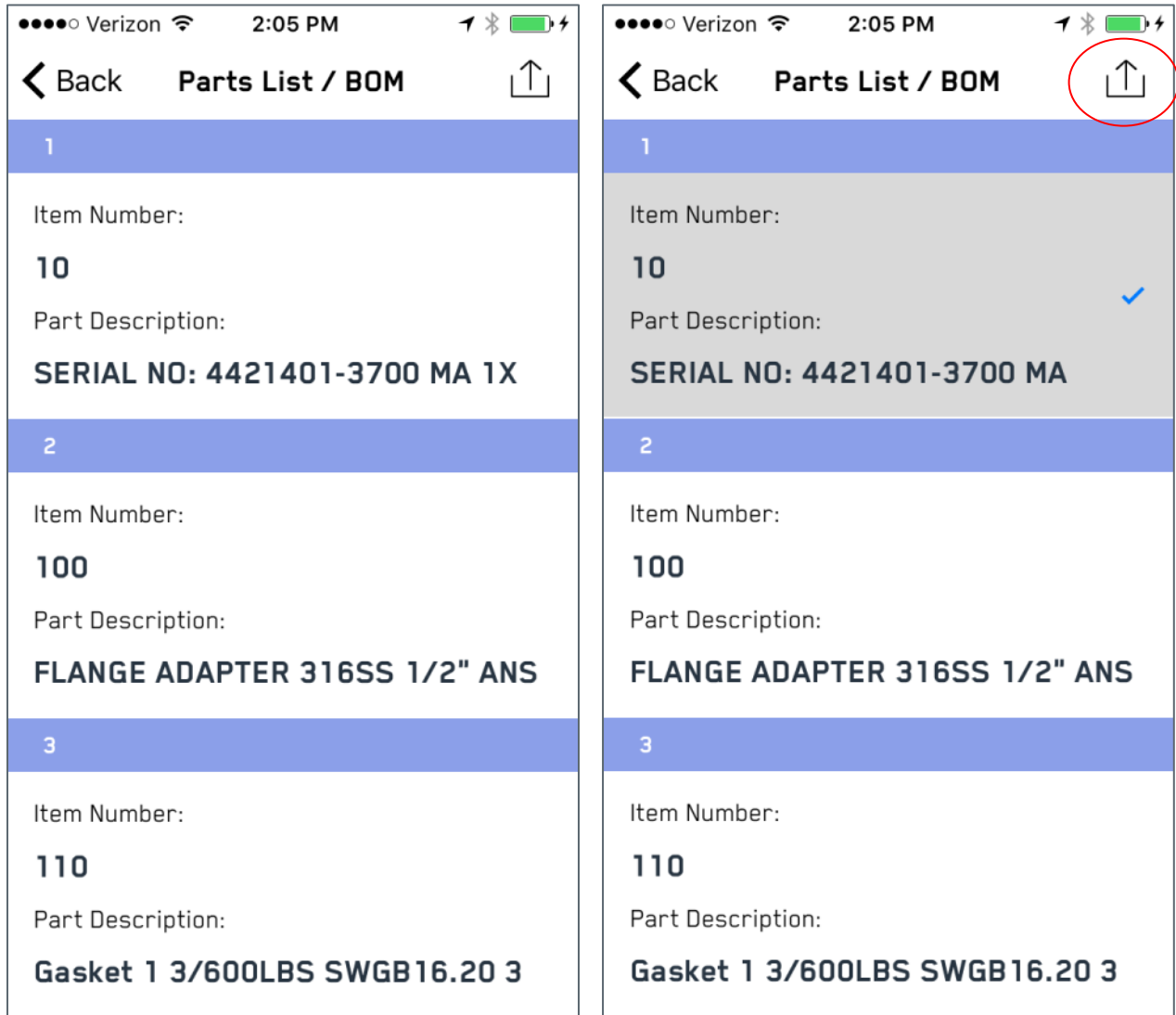

Figure 46: Item 10 information selected for email export

PUMP CURVE

The “Pump Curve” page allows users to easily download, view and save/send a PDF version of the pumps performance curve. This feature is only available for valid ITT Goulds Pumps S/Ns. To view the curve, simply select “Pump Curve” under the Product Information Heading. Once the curve loads you can zoom in and out using standard touchscreen commands or you can save/send the file by tapping the upwards arrow in the upper right hand corner. See Figure 47.

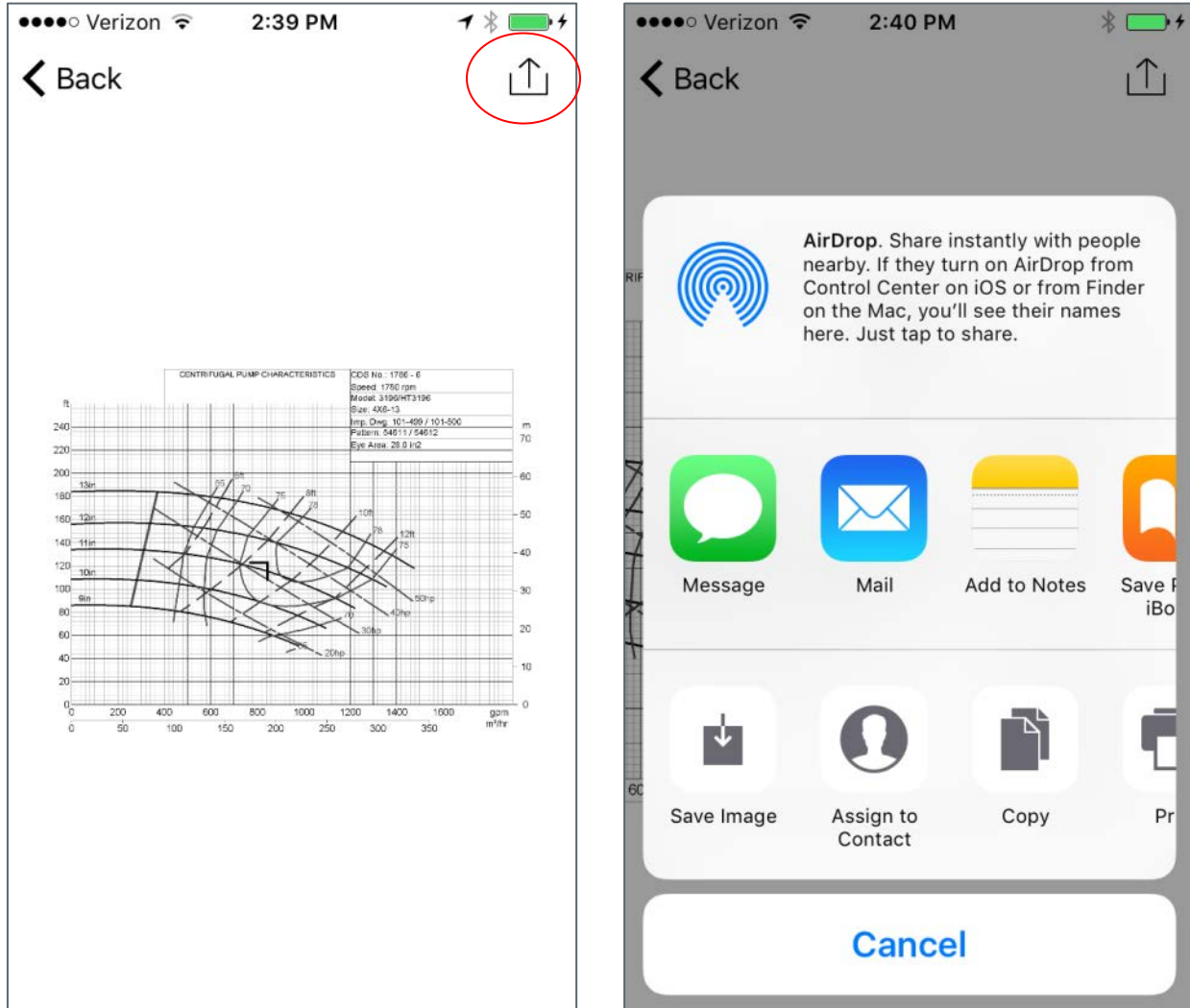

Figure 47: Pump Curve can be saved or sent like standard image file

COMMANDS

Occasionally the need may arise to refresh the i-ALERT2 devices stored data. For instance after a machine is repaired or if a device is moved to another piece of equipment. The “Commands” page contains commands that can be sent to update or refresh the i-ALERT2 monitor as necessary.

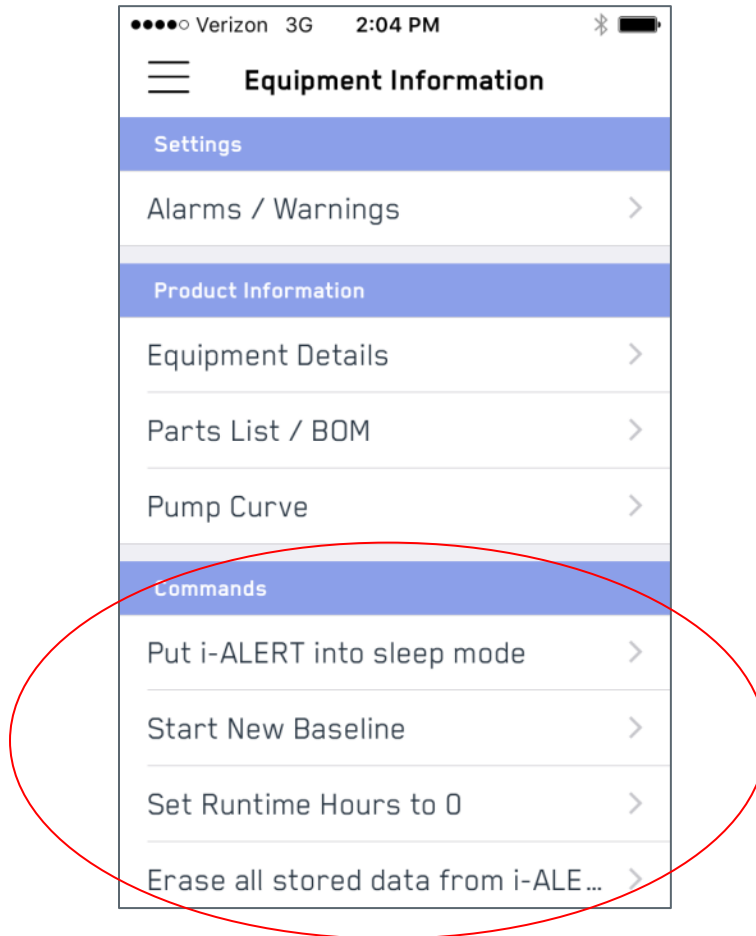

Figure 48: Allowed commands

A brief description of each command is listed below:

Put i-ALERT into sleep Mode: device will go into a very low power consumption mode and does not acquire any data until it is awakened. (Note: A magnet is needed to reawaken the system.)

Start New Baseline: Tells the i-ALERT2 monitor to perform the baseline procedure to establish new Alarm/Warning limits. The device will perform a series of measurements over approximately a day of running to calculate its new baseline.

Set Runtime Hours to 0: Resets run time counter to zero.

Erase all stored data from i-ALERT: Completely erases all stored measurement data. Can be used to “wipe” an i-ALERT if it is being transferred to another machine.

REPORT GENERATOR

The Report Generator function allows the user to export several condition monitoring reports. Currently, reports can be created that show 30 day and 90 day trends of the vibration/temperature as well as the stored FFTs on that i-ALERT2 device. See figure 49.

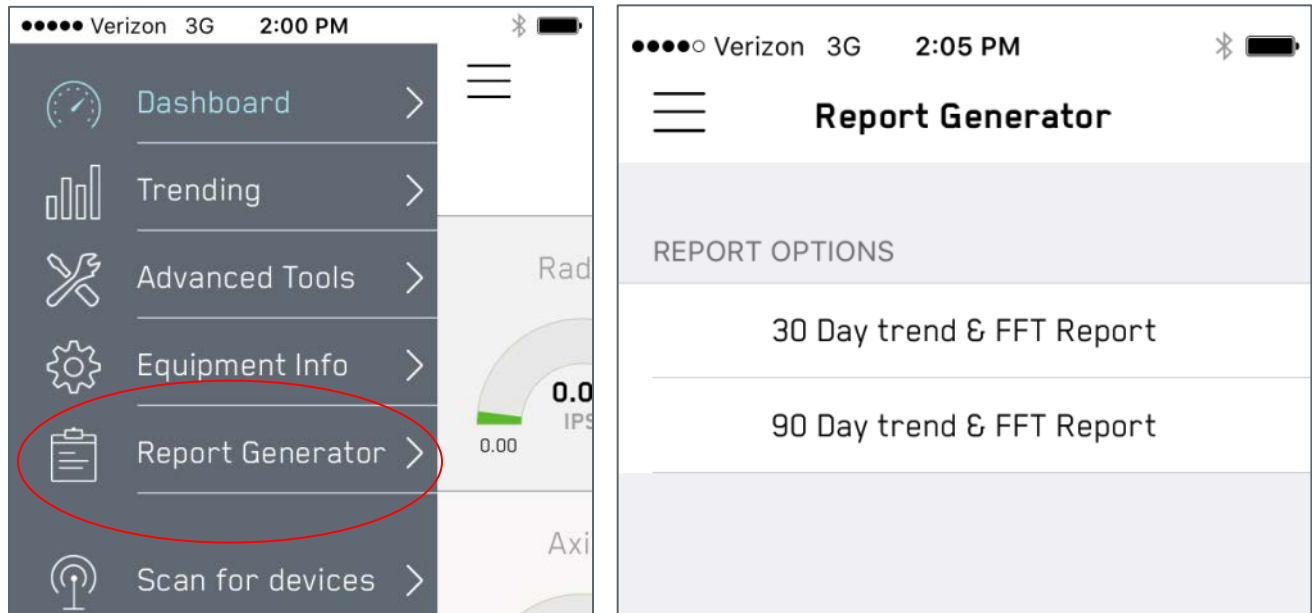

Figure 49: Standard reports are available

Once a report has been generated it can be sent or saved using the upwards arrow icon in the upper right hand corner of the page.

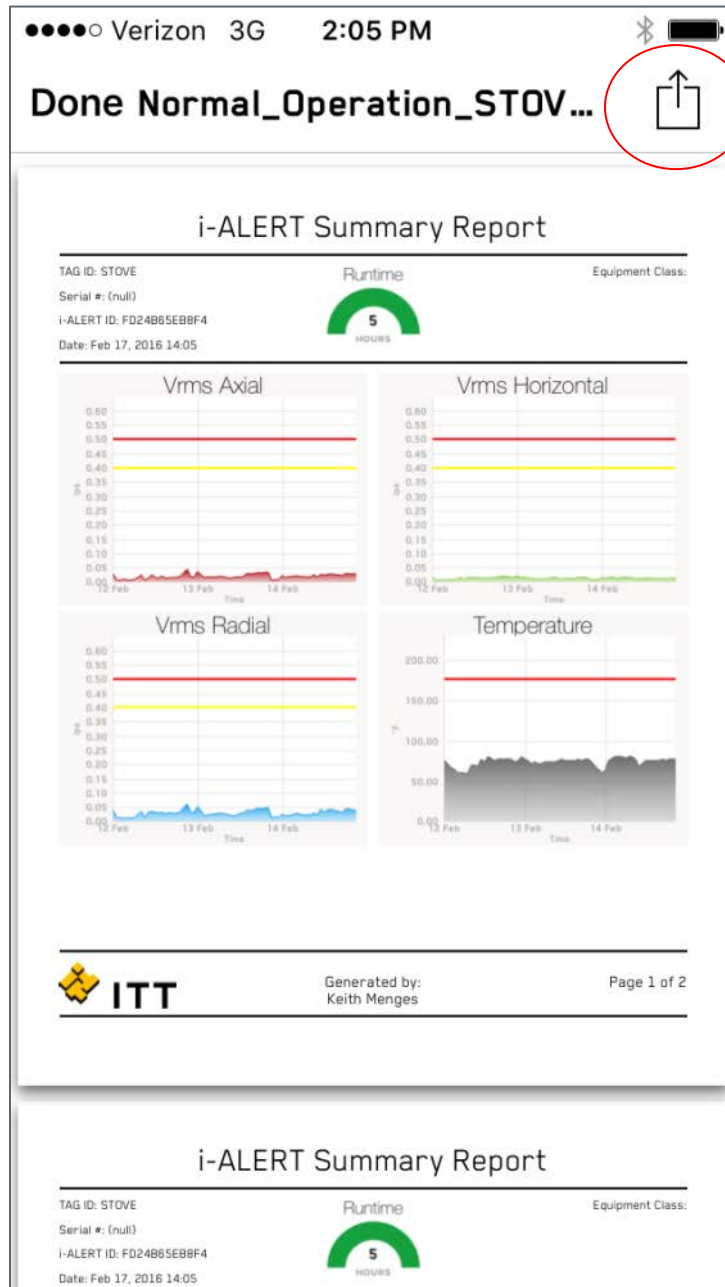

Figure 50: Export standard reports in PDF

HELP/FAQ

The Help/FAQ section provides useful tools in the event you encounter a problem or need additional assistance with the i-ALERT2 or mobile application. Within the Help/FAQ menu you can access the FAQ or Troubleshooting documentation for the product. (Internet connection is required). You also access ITT's website, contact us via email, or view the software policy information.

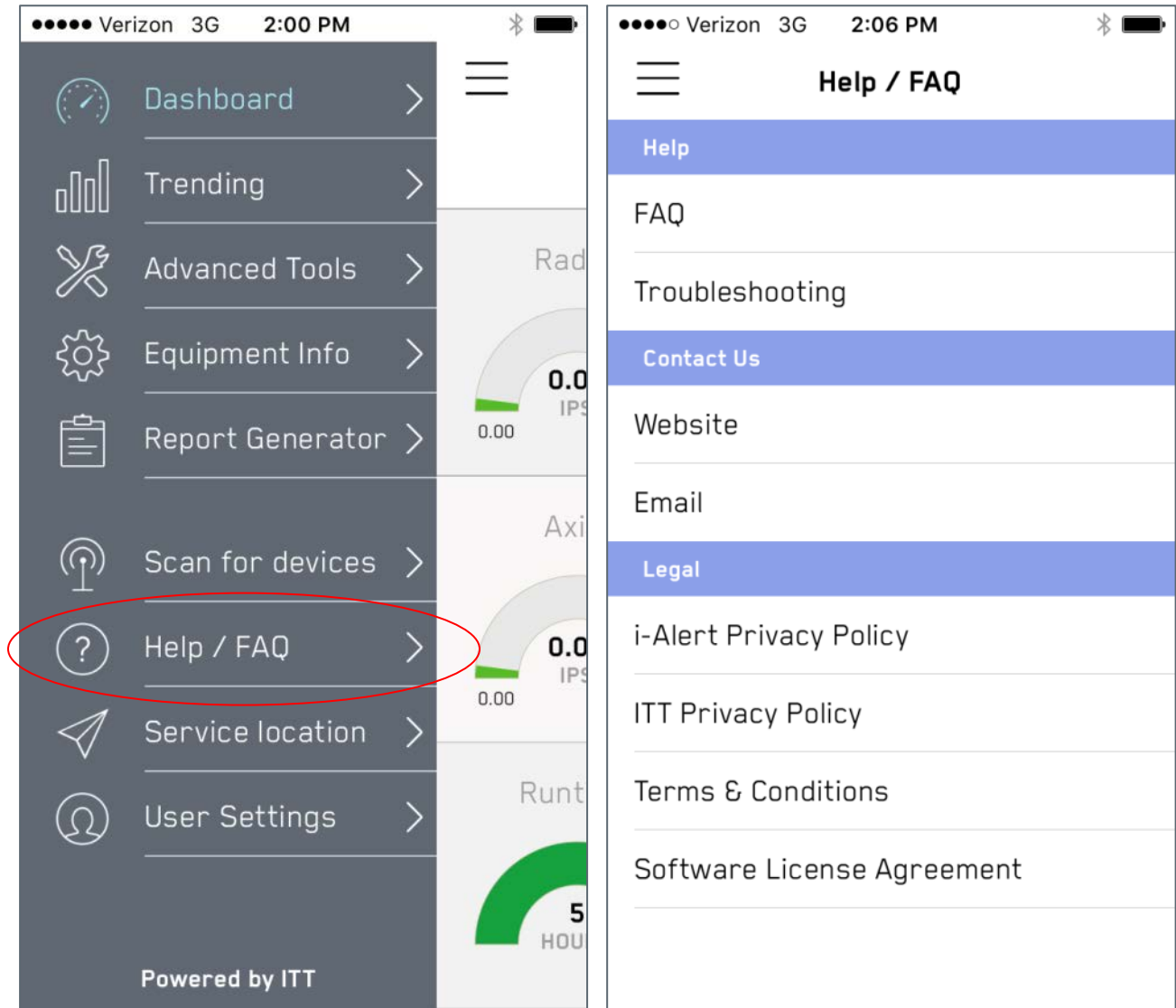

Figure 51: Help/FAQ menu offers additional tools and links

SERVICE LOCATOR

ITT makes it easy to get in touch with local resources that can assist with equipment repairs, spare parts, and field service. Upon tapping the “Service Locator” tag in the main menu, you will be prompted to allow access to your location in order for the application to locate the nearest service center or sales office. Tap the pin with the wrench icon to bring up the service center contact information.

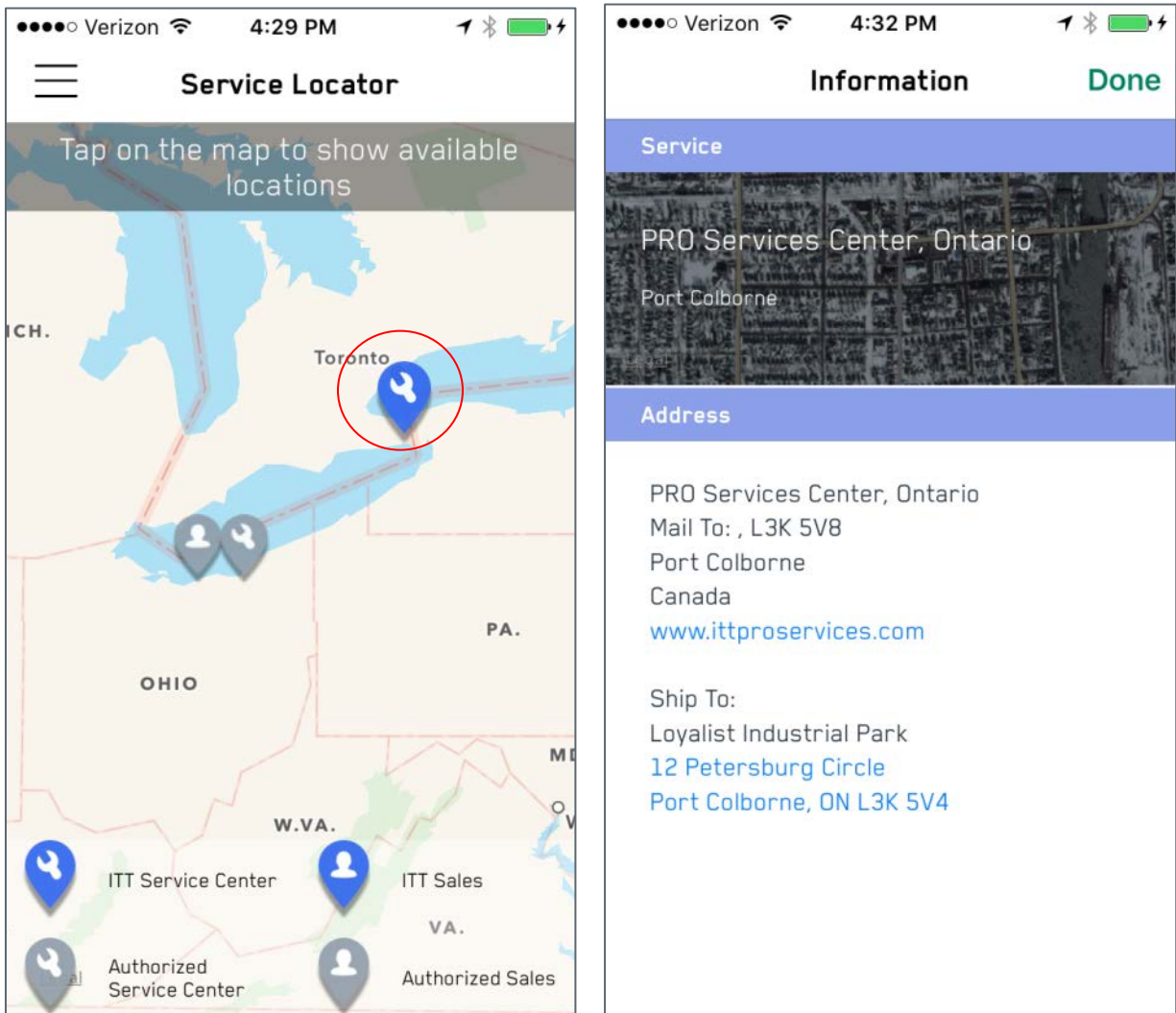
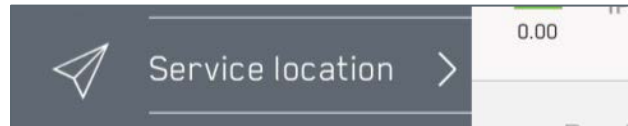

Figure 52: Service locator finds nearest sales or service centers

USER SETTINGS

The “User Settings” menu allows you to change your account details including your name and password. It also allows you to adjust the unit system and specify FFT options.



To change between English and Metric system units, use the function buttons shown in Figure 53.

The FFT can be adjusted to either minimize data collection time or maximize accuracy. For the shortest data collection time, choose Short (20sec). To maximize amplitude accuracy for diagnostics and troubleshooting, change this to Long (60sec). Note, resolution does not change; it is fixed at 1 Hz and is not configurable.

The FFT display can also be adjusted to display in Hz, CPM (Cycles per Minute) or Orders (multiples of shaft speed).

FFT Chart smart zoom: This feature minimizes white space on the FFT chart. ITT Recommends leaving it enabled.

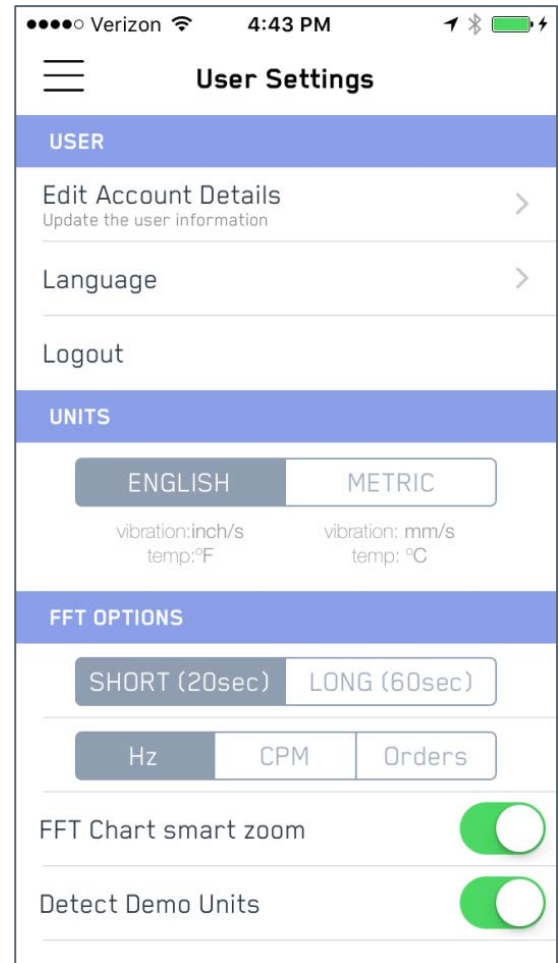

Figure 53: Adjust units in user settings

TECHNICAL REFERENCES

1. Moore, Ron. *Making Common Sense Common Practice. Models for Manufacturing Excellence Third Edition*, Elsevier, Copyright 2004
2. Crawford, Arthur. *The Simplified Handbook of Vibration Analysis Volume II*, Computational Systems Incorporated, Copyright 1992
3. Eshleman, Ronald. *Machinery Vibration Analysis: Diagnostics, Condition Evaluation, and Correction*, Vibration Institute, Copyright 2002

Wherever you are, we're there too.



Reliability has no quitting time.

Building on over 160 years of Goulds Pumps experience, PRO Services provides an array of services focused on reducing equipment total cost of ownership (TCO) and increasing plant output, including predictive monitoring, maintenance contracts, field service, engineered upgrades, inventory management, and overhauls for pumps and other rotating equipment.

Your Total Solution For Equipment Life Cycle Optimization

